

User Guide For
Manifold Block
(Product Part #s 300-145, 300-150, 300-155)



Document #180925001
Document P/N 100-134

SuperMask, Kirby Morgan, DSI, Diving Systems International, EXO, SuperFlow and DECA are all registered trademarks of Kirby Morgan Dive Systems, Inc. Use of these terms to describe products that are not manufactured by KMDSI is not permitted.

The two dimensional images (such as photographs and illustrations) of our products are © copyrighted and trademarks of Kirby Morgan Dive Systems, Inc. The three dimensional forms of our products are trademark/trade dress protected.

© Kirby Morgan Dive Systems, Inc. All rights reserved. This user guide is made available for the express use of owner of this Kirby Morgan product. No part of this user guide may be reproduced, stored in any retrieval system, or transmitted, or used in any form or by any means, whether graphic, electronic, mechanical, photocopy, or otherwise by technology known or unknown, without the prior written permission of Kirby Morgan Dive Systems, Inc.

WARRANTY



USE ONLY KIRBY MORGAN® GENUINE PARTS

Kirby Morgan Dive Systems Inc., (KMDSI) warrants every new helmet, BandMask®, Full Face Mask, SCUBA regulator or air control system (KMACS 5) (each, a Product) to be free from defects in workmanship for a period of three hundred sixty five (365) days from the date of purchase from a KMDSI authorized dealer. This warranty covers all metal, fiberglass, and plastic parts, but does NOT cover rubber parts, communications components, head cushions, chin cushions, or foam spacers.

Any defect of the product in workmanship or material covered by this warranty discovered within three hundred sixty five (365) days from the date of purchase must be promptly communicated in writing to the nearest authorized KMDSI dealer or (if no such dealer in the buyer's country) contact KMDSI directly at (805) 928-7772. No Product returns will be accepted by KMDSI without a returned merchandise authorization (RMA) number from KMDSI. Upon receipt of the RMA from KMDSI, the buyer should return the defective Product or part, freight prepaid, to an authorized KMDSI dealer or the KMDSI plant, as directed by the RMA department. KMDSI will repair or replace the Product at no charge, within a reasonable time, as it deems necessary.

THIS WARRANTY IS NULL AND VOID IF:

- 1) The Product is not registered with KMDSI within ten (10) days of purchase, or
- 2) The Product has not been properly serviced and/or maintained by KMDSI factory trained/approved personnel, according to factory recommended procedures provided in the manual, along with the KMDSI Appendices Checklists, and/or Product updates have not been performed as recommended by KMDSI, or
- 3) Unauthorized attachments or modifications have been made to the Product, or
- 4) The Product has been used for purposes other than those for which it was designed, or otherwise has been abused, misused, or subjected to unusual conditions, or the Product's intended service has been exceeded.

EXCEPT AS SPECIFICALLY PROVIDED HEREIN, THERE ARE NO OTHER WARRANTIES, EXPRESS OR IMPLIED, INCLUDING, BUT NOT LIMITED TO, ANY IMPLIED WARRANTIES FOR MERCHANTABILITY OR FITNESS FOR A PARTICULAR PURPOSE. THE HELMETS, BANDMASKS AND AIR CONTROL SYSTEMS COVERED BY THIS WARRANTY ARE MARKETED AND SOLD BY KMDSI SOLELY FOR COMMERCIAL OR INDUSTRIAL USE AND ARE NOT A CONSUMER PRODUCT INTENDED FOR PERSONAL, FAMILY, OR HOUSEHOLD USE.

In purchasing any Product subject to this warranty, the buyer agrees that its sole and exclusive remedy and KMDSI's entire obligation in contract, tort, or otherwise under this contract will be repair or replacement at KMDSI's option of the Product or any parts which KMDSI determines during the applicable warranty period are defective in workmanship or material covered by this warranty. All exchanged parts are the property of KMDSI. The buyer's exclusive remedy and KMDSI's entire liability in contract, tort, or otherwise is the payment by KMDSI of the buyer's actual damages up to but not to exceed the amount paid by the buyer for the Product.

In no event shall KMDSI be liable to the buyer for indirect, special, incidental or consequential damages (including, but not limited to, damages for lost profits, lost sales, loss of business opportunity, or for injury to persons or property arising out of the use of the Products). Any claim or action for breach of warranty must be commenced within one year following delivery of the Product to the buyer.

Buyer acknowledges that this warranty is the sole and exclusive warranty of the Product and that it supersedes any and all oral or written representations and undertakings between KMDSI, its dealers, and the buyer relating to the Products. This warranty allocates the risks of product failure between KMDSI and the buyer, which allocation is recognized by both parties and is reflected in the price of the goods. The buyer acknowledges that they have read this agreement, understand it, and are bound by its terms.

IMPORTANT: Please register your purchase online at www.kirbymorgan.com/support/product-registration-form. If you have a problem with the online registration, please contact your Kirby Morgan dealer, or Kirby Morgan directly by calling (805) 928-7772, or email sales@kirbymorgan.com.

Kirby Morgan® thanks you for your purchase.

This page intentionally left blank

Table Of Contents

5	Definitions of Signal Words Used in this Guide
6	Diving in the Surface Supplied Mode
7	Testing the Manifold Block
8	Testing The One-Way Valve
9	Testing The Emergency Valve
9	Diver's Harness
10	Installing the Manifold Block on the Harness
11	Bailout Bottle (Emergency Gas Supply)
11	Overpressure Relief Valve P/N 200-017
12	Manifold Block Maintenance
16	Disassembly of the Emergency Gas Supply Valve P/N 505-070
19	Overpressure Relief Valve P/N 200-017, Overhaul Procedures
26	Maintenance Record

Definitions of Signal Words Used in this Guide

The original language of the Kirby Morgan Manuals is English. Translation into other languages will be provided upon request. KMDSI may charge a fee for these services.

Throughout this user guide we will use certain words to call your attention to conditions, practices or techniques that may directly affect your safety. Pay particular attention to information introduced by the following signal words:

DANGER

This word indicates an imminently hazardous situation, which if not avoided, could result in death or serious injury.

WARNING

This word indicates a potentially hazardous situation, which, if not avoided, could result in death or serious injury.

CAUTION

This word indicates a potentially hazardous situation, which if not avoided, may result in minor or moderate injury. It may also be used to alert against unsafe practices.

This operation user guide contains important safety information and should always be available to those personnel operating this equipment. Read, understand, and retain all instructions before operating this equipment to prevent injury or equipment damage.

If you sell or loan this equipment to another person, be sure that this user guide accompanies the gear when you transfer possession to them.

It is important for the user of this equipment to understand that we at Kirby Morgan consider ourselves to be only a part of the process of diving equipment design. We welcome and encourage all input from our customers. Our goal is to provide the highest quality diving equipment and service possible. If you have any questions or comments, please feel free to contact us at (805) 928-7772 or visit our web site at www.kirbymorgan.com.

If you use an EXO-26 or other full face mask for surface supplied diving, a manifold block which has a one-way valve (also referred to as a “non-return” valve) and provides for correct attachment of the umbilical is essential. The emergency gas supply valve on the manifold block controls the flow of the bailout supply. There are three different fittings available on the one-way valve:

P/N

- 300-145 3/8" SCUBA fitting
- 300-150 3/8" oxygen fitting
- 300-155 #6 JIC fitting

Diving in the Surface Supplied Mode

If you have not been trained in the proper use of surface supplied diving equipment we strongly recommend that you complete a training course in the use of this equipment prior to diving surface supplied.

⚠ WARNING

Many full-face masks are not equipped with a one way valve (non-return valve) as supplied from the factory. For surface supplied diving, the diver must use a manifold block equipped with a one way valve. This will help to prevent a “squeeze” in the event of a loss of the topside air supply. Without this valve, if a squeeze like this occurs, the diver will suffer serious personal injury or death.

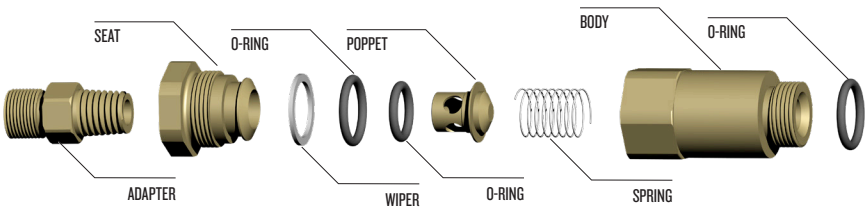

Components of the one-way valve

The one-way valve is a very important component. It prevents the flow of air out of the mask in the event of a sudden lowering of pressure in the umbilical supply hose due to an accidental break in the hose or fitting. Not

only would the emergency air be lost if the one-way valve failed (concurrent with a hose or fitting break) but the diver could be “squeezed,” a very serious accident. Do not dive in the surface supplied mode without a one-way valve in the breathing system mounted on the diver’s harness.

At a minimum, if you are doing surface supplied diving, the following systems and components must be in place and in proper working condition.

1. **Air Supply:** Either a low pressure compressor or high pressure air bottles with a pressure reducing regulator capable of being manually adjusted to 140 p.s.i over bottom pressure.
2. **Dive Control System:** An air management box to control the flow of air to the diver or divers (such as the KMACS-5 offered by KMDSI).
3. **Divers Umbilical:** Hose bundle consisting of air supply hose, pneumofathometer hose (depth sensing), communications wire and strength member/strain relief (the strength member may be the entire hose assembly, if so designed).
4. **Diver’s Manifold Block:** A metal block that has a one-way valve that the umbilical attaches to, an emergency valve that the bailout system attaches to, and L.P. ports for attaching the mask hose, dry suit inflators and other accessories.
5. **Bailout System:** Consisting of a harness, bailout bottle, first stage regulator with overpressure relief valve. This system connects to the emergency valve on the divers manifold block assembly by a hose. Also known as an Emergency Gas System.
6. **Communications System:** Provides hard wire communication between diver and topside.

⚠ WARNING

Do not dive without a diver worn Emergency Gas System. If the main gas supply is lost, you will have nothing to breathe and may drown.

Testing the Manifold Block

Prior to assembling a bailout system, the one-way valve and emergency valve should be tested for proper function.

Equipment Needed:

- Manifold Block
- Bailout bottle

- 1st Stage regulator w/octopus and scuba reg hose attached
- DCS system with an umbilical supply hose
- Bucket of water

Testing The One-Way Valve

1. With all the accessory holes plugged on the manifold block, attach the SCUBA type regulator hose from a first stage regulator that also has an octopus attached, to the emergency valve on the manifold block assembly. The octopus will be used for depressurization once the test is concluded.
2. Connect the first stage to the bailout bottle, open the emergency valve all the way, and pressurize the system.
3. Place the pressurized manifold block in a bucket of water and check the one-way valve for leaks. No air should leak through the one-way valve or from anywhere else on the manifold block assembly. If there is a leak, the one-way valve **MUST** be rebuilt or replaced.
4. As a secondary test, close the emergency valve trapping pressure inside the manifold block assembly and relieve the pressure on the first stage using the octopus.

Disconnect the hose from the emergency valve.

5. Quickly open the emergency valve by turning the knob. You should hear the trapped air escaping through the emergency valve.

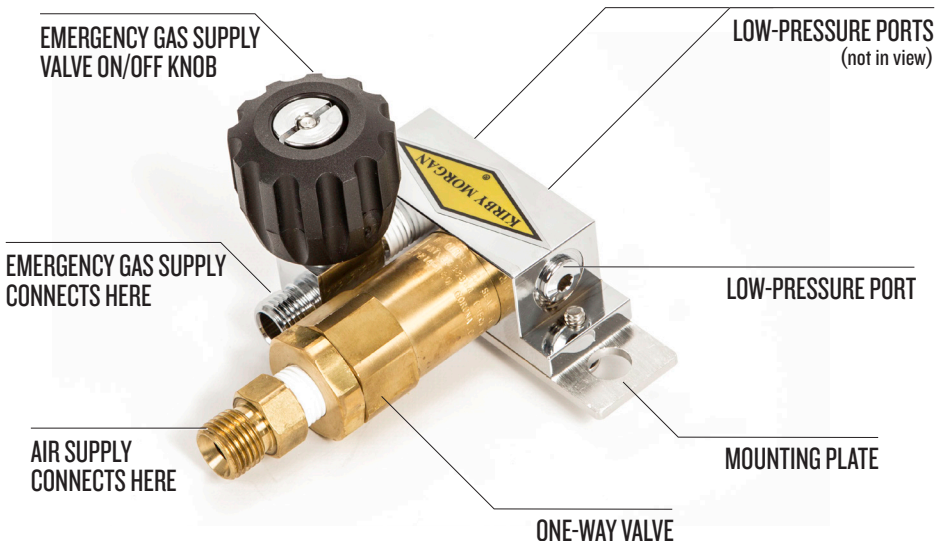

Testing The Emergency Valve

- 1) With all the accessory holes plugged on the manifold block, attach the umbilical hose to the one-way valve.
- 2) Make sure that the emergency valve is closed all the way and pressurize the umbilical.
- 3) Place the pressurized manifold block in a bucket of water and check the emergency valve for leaks. No air should leak through the emergency valve or from anywhere else on the emergency valve assembly or manifold block assembly. If there is a leak, the emergency valve **MUST** be rebuilt or replaced.
- 4) Turn umbilical off and open the emergency valve to depressurize the system and disconnect the hose.

Diver's Harness

The harness provides an attachment point for the manifold block, tools the diver may use while in the water, and the “D” ring where the umbilical shackle connects. The umbilical shackle must connect to the strength member of the umbilical. The manifold block attaches to the harness and the harness is the primary attachment point for the diver’s umbilical using a shackle. Arrange the umbilical so it attaches to the harness, then to the manifold block on the harness. This helps eliminate the possibility of a direct pull on the diver’s mask by topside. The harness may also be used to lift an unconscious diver from the water and should be of sturdy construction.

The diver must always wear a bailout bottle attached to a diver's harness for surface supplied diving.



The diver's umbilical must always be connected by a snap hook to the harness. Note the submersible pressure gauge used to monitor the bailout supply.



⚠ WARNING

Never dive without attaching the umbilical to some type of harness or clip on the diver's body. Never allow the umbilical to pull on the mask directly or the diver could suffer a neck injury, or the mask could be pulled off the diver's head causing death by drowning.

Installing the Manifold Block on the Harness

The manifold block assembly is designed to be worn on the diver's harness. Most divers prefer to attach the manifold block to the right side of the diver's harness. The shackle which attaches the umbilical to the harness "D" ring, is usually located on the left side. After attaching the umbilical to the "D" ring on the left side of the harness, the umbilical is normally routed behind the diver's back to the manifold block.

To attach the manifold to the diver's harness:

1. Remove one of the screws which holds the mounting plate on the manifold block body and loosen the other screw to provide enough clearance for a harness strap.
2. Swing the plate to one side and position the manifold block on the harness.
3. Swing the plate back into the correct mounting position and thread the screw through the plate and into the manifold body.
4. Tighten both screws until the harness is compressed between the manifold and mounting plate holding the manifold block assembly in place.

The mounting plate secures the manifold block to the diver's harness.

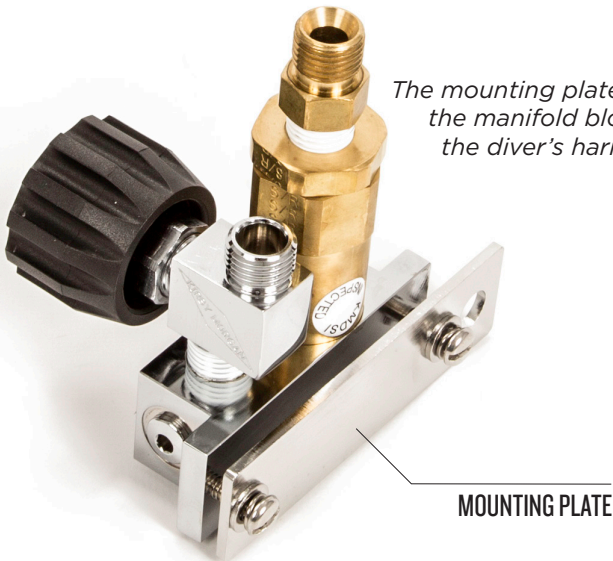

Bailout Bottle (Emergency Gas Supply)

The diver should always dive with a bailout bottle when diving surface supplied, no matter how experienced or what the water depth. Should the diver become unexpectedly entangled underwater, or if the topside air supply fails, the bailout bottle must provide the few extra minutes of air the diver needs to deal with the emergency and return to the surface.

The size of the bailout bottle should be determined by the water depth, the penetration distance, or the probability of entanglement of the diver. The diver must have sufficient air in the bailout bottle to make an ascent at the correct ascent rate and complete a precautionary decompression stop or any required decompression.

Overpressure Relief Valve P/N 200-017

The first stage regulator must have at least two low pressure ports. One port is used for the connector hose to the emergency valve and the second is used to install an overpressure relief valve (P/N 200-017). If the first stage develops an intermediate pressure creep, the full pressure of the tank could be placed on the low pressure hose. This could cause the hose to burst. The overpressure relief valve will bleed off any leak.

Note that the overpressure relief valve is not supplied with the manifold block, but must be purchased separately.

⚠ WARNING

Never dive without an overpressurization relief valve installed on the EGS regulator (1st stage). Without the relief valve if the EGS regulator develops an internal leak, the full pressure of the EGS cylinder would be placed on the low-pressure EGS hose and the Emergency Gas Supply Valve. This could cause the low-pressure hose to burst resulting in the complete loss of the EGS system.



The overpressure relief valve should be installed on every first stage used for bailout. KMDSI P/N 200-017



NOTE

This valve can be adjusted for various relief pressures.

⚠ WARNING



Ensure the overpressure relief valve is only installed in a low-pressure port of the first stage regulator. Installation in a high-pressure port will lead to loss of EGS supply and possible serious personal injury if the valve fails.

Manifold Block Maintenance

Daily- A daily pre-dive inspection should be done prior to using the Manifold Block. Carefully inspect the assembly for any sign of damage or worn components.

Tools: open end wrenches, 1", 1/16", 9/16", 5/8" and a 5/32" Allen wrench.

1. Check to ensure all the port plugs are installed and are tight.
2. Check to ensure the emergency gas supply whip is installed and tight, on the emergency valve.

- Using a $\frac{1}{16}$ " open-end wrench, check to ensure the packing nut on the emergency valve is snug.



Do not over tighten. The valve handle should turn freely. Check to ensure the packing nut does not turn -when a light force is applied with the wrench.

NOTE

- Ensure the one-way valve and umbilical adapter are securely in place.
- Test the one-way valve by sucking on the inlet fitting with your lips. If any air is drawn through the valves the valve must be rebuilt or replaced.

Post Dive Procedures

Daily post dive maintenance of the manifold block requires a brushing with a solution of mild soapy water and a thorough rinsing with fresh water. If hoses have been removed, ensure port plugs have been installed and the umbilical connection has been capped or bagged.

Annual Overhaul of the Manifold Block Assembly.

The KMDSI manifold block should be rebuilt on an annual basis, or when damage or corrosion is suspected or found.

Parts required:

Manifold Repair Kit P/N 325-095

Tools and Materials Needed:

- Vise and Clean Rags
- $\frac{9}{16}$ ", $\frac{5}{8}$ ", $\frac{11}{16}$ " and (2) 1" Open End Wrenches
- $\frac{5}{32}$ " Hex Wrench
- Large Flat Blade Screwdriver
- Torque Wrench, 0-150 inch lbs.
- Soft Nylon Brush
- O-ring Pick
- White Vinegar

Disassembly of Manifold Block

- Remove the two flat head screws and washers from the manifold backing plate, and remove the plate.

2. Remove all hoses and port plugs. Remove the O-ring from each plug and place the plugs in a solution of 5% white vinegar and water.
3. Using a soft jaw vise or a rag wrapped around the manifold block to keep from marring the finish, remove the one-way valve from the manifold block using the 1" wrench.



The one-way valve must be removed from the manifold block before the emergency valve.

NOTE

4. Using the 5/8" open-end wrench, loosen and remove the emergency valve from the manifold block. Remove Teflon® tape, clean and inspect threads and EGS body.
5. Place the manifold block body in a solution of vinegar and water, and allow to soak while the other components are being disassembled. Using the 1" wrench and the 5/16" wrench, loosen and remove the umbilical adapter fitting from the one-way valve. Remove Teflon® tape from fitting. Place it in the vinegar solution.
6. Carefully clean the manifold block body with a nylon brush and vinegar solution. Remove all traces of old lubricants, dirt and corrosion. Rinse with fresh water and blow dry with compressed air or allow to air dry. Using the nylon brush, clean the manifold plate and umbilical adapter. Air or blow dry. Inspect all threaded ports for any damage.

Overhauling the One-Way Valve P/N 555-195

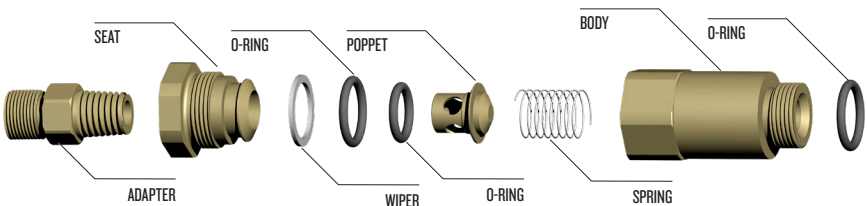

Components of the one-way valve

Tools Required:

- Soft Jaw Vise
- 1 inch open end wrench attachment on torque wrench
- (If no vise is available use a backup 1 inch open end wrench)

- One-way valve kit P/N 525-330 (included in manifold repair kit P/N 325-095).

CAUTION

Do not use pliers on the main body of the one-way valve. You may damage the valve if pliers are used.

To disassemble and inspect the one-way valve assembly:

1. Use two wrenches or hold the hex part of the body in a soft jaw vise while removing the seat with a wrench. As the seat is removed, the wiper and the O-ring slide out in place in a groove on the seat. The poppet and the poppet O-ring usually come out in the seat being followed by the spring.

The only functional part remaining in the valve body is a non-moving, pressed-in cage. The function of the cage is to contain the poppet during high gas flows.

2. Inspect the body interior for foreign matter of any type and clean, if necessary. Clean in accordance with the KMDSI cleaning instructions. If corrosion is present, clean using the acidic solution as outlined in the KMDSI cleaning procedures.
3. Inspect the seat, wiper, O-ring, poppet O-ring and poppet for wear, replace if necessary. Be sure each part is clean and all components are lightly lubricated with the appropriate lubricant. A repair kit is available for replacement parts, (P/N 525-330). All O-rings should be replaced during normal/annual overhauls.
4. Be careful to wipe the poppet and poppet O-ring thoroughly, removing nearly all silicone to prevent foreign materials from sticking to these components.
5. Inspect the spring and clean or replace as needed.

Reassembly of the One-Way Valve

1. Slide the new O-ring over the poppet.
2. Insert the new spring into the valve body, followed by the poppet.
3. Next, install the new O-ring and new wiper on the seat. Thread the seat into the valve body.
4. Tighten the seat to 150 inch lbs. (17 newton meters) with a torque wrench while holding the body in a soft jaw vice or wrench.

⚠ WARNING

Do not allow any Teflon® tape to cover the end of the adapter, or to enter the one-way valve. Loose pieces of Teflon® tape can interfere with the performance of the one-way valve or the regulator and may block the diver's air supply. This could lead to death through suffocation.

5. If the adapter has been removed, it must be cleaned and wrapped with Teflon® tape.



NOTE

The one-way valve must be installed in the manifold block after the emergency valve.

6. Test the operation of the valve.

Disassembly of the Emergency Gas Supply Valve P/N 505-070

Tools Required:

- 1¹/₁₆ inch Open End wrench
 - 1 inch Open End wrench
 - 1¹/₁₆ inch Open End attachment Torque Wrench
 - 3⁸/₈ inch Slotted Flat Blade Screwdriver
 - Soft Jaw Vice
 - Lubricant
 - Teflon® Tape
 - Normal minimum overhaul replacement parts: None
1. Remove the lock nut, spring, and knob.
 2. Undo the packing nut. When the packing nut is free of the threads of the emergency valve body, back out the stem until it is free of the emergency valve body.
 3. Remove the washer from the stem.

Cleaning and Lubricating

1. Clean all the metal parts in a soap and water solution, followed by cleaning with a 5% dilute solution of white vinegar/water. Rinse with fresh water. Clean all parts.
2. Inspect the packing and washer for wear and replace if necessary. Normally the packing will last a very long time and does not require replacement as long as the valve operates smoothly and does not leak. To replace the packing place the packing nut in a vise and carefully work the packing out with a small screw driver, taking care not to damage the threads of the packing nut. Replace the washer, if necessary.

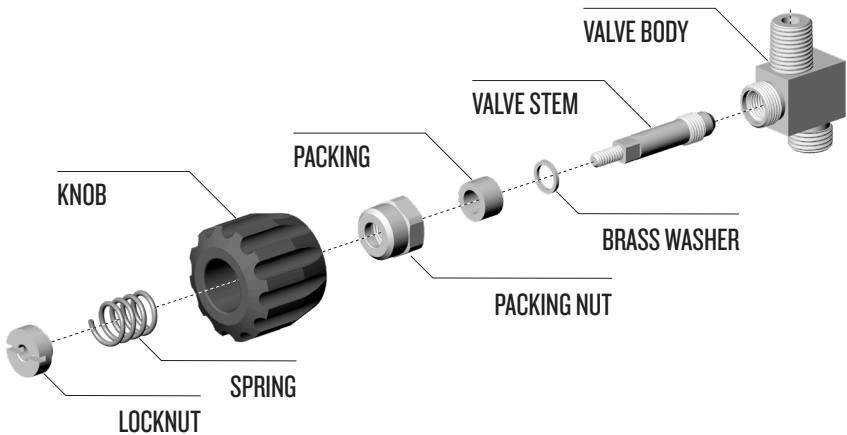

Components of the emergency gas supply valve

3. Inspect the stem seat for unevenness or wear to ensure the conical seat surface is smooth and free of corrosion or damage. Replace if necessary. It must also be replaced if the stem is bent. Damage will include damaged threads, and/or rounded flats that engage the control knob. Also inspect the shaft.
4. Check the seat, inside the emergency valve body, for wear or unevenness, galling and corrosion. To clean up the seat surface use a pencil eraser to buff the surface. Inspect all threaded surfaces for damage. Replace the emergency valve body if any damage is found.
5. To remove the emergency valve body from the manifold block the one-way valve assembly must first be removed.
6. If the emergency valve body is removed, clean and inspect the pipe threads and inspect for damaged threads, cracking, or distortion. Replace the emergency valve if any damage is present.

Re-tape threads with Teflon® tape, 2 ½ wraps starting two threads back.

Tighten with standard pipe thread tightening procedure. Reinstall the emergency valve body into the manifold block before installing the one-way valve assembly.

⚠ WARNING



Do not use any sealant on pipe threads on Kirby Morgan products other than Teflon® tape or other approved sealants. Other sealants may not be oxygen compatible and may lead to fire or explosions which may cause severe personal injury or death.



Use only Teflon® tape to seal the emergency valve in the manifold block.

Reassembly of Emergency Valve, P/N 505-070

1. Lightly lubricate the stem threads in the body as well as the packing nut threads.
2. Lightly lubricate the stem shaft and threads. Place washer onto stem.
3. Screw the stem into the emergency gas valve body. Rotate the stem until it is seated all the way in then, back it out ½ turn.
4. Thread the packing nut onto the emergency valve body. Run the nut in and tighten slightly with a wrench.
5. Inspect the emergency gas valve knob for wear and damage. Ensure the flats that engage the valve stem shaft are not rounded, cracked or damaged. The valve knob should not have rotational play greater than ¼ of a turn.
6. Place the emergency gas valve knob onto the stem and rotate the stem all the way out, then back again. The rotation must be smooth. If “hard spots” or unevenness are felt during the rotation, the stem may be bent and could need replacement.
7. Remove valve knob and tighten the packing nut with a torque wrench until moderate resistance is felt when turning the knob. Torque to 45 inch lbs. after seating.

8. Place the spring, knob and locknut onto the valve stem.
9. Tighten the locknut until its top is flush with the top of the knob. The assembly is now complete and ready for testing.
10. Test the valve by first shutting the EGS Valve closed. Pressurize to a minimum of 135 PSI (9.3 bar) using the LP hose (bailout whip) from the first stage on an EGS cylinder that contains a minimum of 500 PSI (34.4 bar). Allow system pressure to stabilize, and then shut the EGS supply cylinder valve.

Method 1) Note time and final stabilized system pressure. Perform the leak check for minimum of five minutes covering the entire valve body with a mild soap solution and look for forming bubbles. Also ensure there is no gas flowing or pressure drop in the system.

Method 2) Place valve into a bucket of clean water and look for bubbles for a minimum of 30 seconds.

⚠ WARNING

A leaking Emergency Gas Valve assembly can cause the diver to exhaust his entire EGS (bailout) without his knowledge. This may lead the diver to mistakenly assume his EGS supply is available when it is not. This could lead to panic or drowning in an emergency. Any worn or damaged components must be replaced.

Overpressure Relief Valve P/N 200-017, Overhaul Procedures

The overpressure relief valve should always be used on all Emergency Gas Supply (EGS/bailout) first stage regulators to prevent the hose from rupturing in the event the first stage pressure creep. The Kirby Morgan overpressure relief body is made of stainless steel.

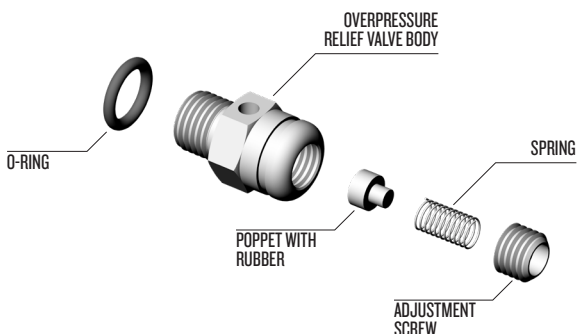

The basic components last a long time but the valve should be disassembled, cleaned, and inspected at least once a year or whenever it fails testing. The valve should be tested monthly. Cleaning and overhaul is easily performed using a nylon brush and a 5% solution of vinegar and fresh water. Cleaning for 15 minutes in an ultrasonic sink, if available, with the 5% vinegar solution is highly recommended.

Rebuild parts are available. Normal replacement parts include the O-ring, soft seat, spring, and hex nut. The O-ring should be replaced at least annually. The other parts require replacement only if worn or damaged. The overpressure relief valve rebuild kit is P/N 225-017.

Tools Required:

- Torque Wrench
- ½" Open-End Wrench Attachment for Torque Wrench
- ⅛" Allen Wrench
- Nylon Brush
- Vinegar, Fresh Water
- Mild Dish Soap
- Ultrasonic Sink, if Available
- Magnifying Glass
- New Valve Body O-ring

Overpressure Relief Valve Disassembly and Cleaning

1. Turn off the gas supply to the first stage regulator, then bleed off any remaining pressure. Remove the first stage regulator from the gas source so it cannot be accidentally turned on, i.e., pressurized.
2. Remove the overpressure relief valve from the regulator body using the ½" open-end wrench.
3. Remove, cut, and discard the overpressure relief valve body O-ring.
4. Using the ½" open-end wrench to hold the bleed/ relief body, use the ⅛" Allen wrench to remove the Allen head adjustment screw. Then, shake out the spring and soft seat.
5. Place all parts in the 5% solution of vinegar and water and allow to soak for 15 to 30 minutes. If using an ultrasonic sink, reduce time to 10 minutes.

6. Using the nylon brush, brush all components to remove corrosion and mineral deposits. Then, rinse with fresh water and blow or air dry.
7. Using the magnifying glass, carefully inspect all components for excessive corrosion and/or damage. Replace the spring and/or adjustment nut, if either part is excessively corroded or shows signs of wear and/or damage.

Inspect the soft seat for nicks, cuts, and wear and replace if any damage is found. Replace the entire assembly if any damage to the valve body is present.



NOTE

A deep groove in the soft seat is normal. Replacement is only necessary if the rubber seat is deteriorated, cut, and/or chipped.

Overpressure Relief Valve Reassembly

1. After cleaning, inspection and/or parts replacement, reassemble the valve by installing the soft seat, spring, and adjustment nut. Screw the adjustment nut down until it is approximately $\frac{1}{2}$ thread from being flush with the top of the valve body.
2. Lightly lubricate a new body O-ring, then install on the valve body.
3. Test the overpressure relief valve according to the test procedure below.

Overpressure Relief Valve Lift Check/Setting

Tools required:

- Adjustable First Stage Scuba Regulator or Controlled Adjustable Pressure Source
- Intermediate Pressure Test Gauge
- Torque Wrench
- $\frac{1}{2}$ " Open-End Wrench Adapter for Torque Wrench
- $\frac{1}{8}$ " Allen Wrench
- HP Air Source (Scuba Tank) with at Least 500 P.S.I.G. (34.4 Bar).
- Mild Dish Soap

The purpose of lift checking the overpressure relief valve is to ensure it operates properly, allowing excess pressure to escape in the event the first stage develops an increasing intermediate pressure leak. Without the overpressure relief valve, high-pressure gas will continue to increase

until the emergency supply hose ruptures, possibly causing injury and a complete loss of the Emergency Gas System (EGS).

This procedure explains the steps necessary for readjusting the overpressure relief valve after it is cleaned, overhauled or any time the valve is tested.

⚠ WARNING



Do not use oxygen, or mixed gas containing more than 23% oxygen by volume, for lift checking the overpressure relief valve. The use of oxygen, or mixed gas, in a high-pressure supply system not designed and cleaned for oxygen service, can result in a fire or explosion causing serious injury or death.

If a first stage scuba regulator is used, it must be able to be adjusted to the desired lifting pressure. The pressure gauge should be compared to a gauge of known accuracy.



NOTE

If the Allen screw on the overpressure relief valve hex nut is rotated too far, too fast, the overpressure relief valve will pop open. This could possibly require the air to be secured at the cylinder or supply source to reset the seat before the adjustment can be accomplished.



NOTE

The overpressure relief valve can be installed in any 1st stage regulator low pressure port.

1. Install the overpressure relief valve in a low-pressure port on an adjustable 1st stage regulator. Or install on the scuba test stand.
2. Install the intermediate pressure gauge in one of the low-pressure ports of the 1st stage regulator.
3. Install the 1st stage regulator on the cylinder. Ensure the overpressure relief valve and intermediate pressure gauge are attached to low-pressure ports.
4. Wet the overpressure relief valve with soapy water to help indicate gas flow.
5. Slowly bring up air pressure while watching the intermediate pressure gauge until the pressure gauge indicates 180- 200 p.s.i.g. (12.40-13.78 bar). If the overpressure relief valve starts venting at a pressure below 180- 200 p.s.i.g. (12.40-13.78 bar), secure the air supply and adjust the

adjustment screw (1) in (clockwise) 1/8th turn. Slowly bring up pressure and recheck.

Continue this procedure as necessary until the overpressure relief valve consistently vents at a pressure between 180- 200 p.s.i.g. (12.40-13.78 bar). If the valve does not start venting when the gauge reads 200 p.s.i.g. (13.78 bar), slowly back out on the adjustment screw (counter clockwise) until the valve starts venting, forming bubbles in the soap solution.

6. After the overpressure relief valve has been adjusted, adjust the 1st stage regulator intermediate setting to 135 p.s.i.g. (9.3 bar), re-wet the valve, then slowly increase the intermediate pressure on the 1st stage regulator one last time to recheck the lift pressure. The overpressure relief valve should start forming bubbles or venting at between 180-200 p.s.i.g. (12.40-13.78 bar).
7. After final lift check reset the regulator back to the appropriate over bottom setting. Remove the intermediate pressure gauge and plug LP port, test is complete.

Overpressure Relief Valve Troubleshooting

Problem: Valve pops open and will not stop flowing:

Check: If while setting the overpressure relief valve the valve pops open and will not stop flowing, secure the air supply valve and allow the valve to reseat. Try the procedure again, ensuring that the supply valve is only slightly cracked open, allowing full test pressure but minimizing high flow potential.

Problem: After resetting the first stage to 135 p.s.i.g. (9.3 bar), the valve continues to leak:

Check: This indicates the valve body, seating surface or the soft seat is either dirty or damaged. Usually, cleaning both the metal body, seating surface in the valve body and the soft seat will fix the problem. If, after cleaning, the problem persists, replace the soft seat and spring and retest the unit. If the seat continues to leak, then replacement of the complete valve will be necessary.

The purpose of lift checking the overpressure relief valve is to ensure the valve operates properly allowing excess pressure to escape in the event the first stage develops a slight intermediate pressure creep. This procedure also explains the steps necessary for readjusting after cleaning or overhaul.

Reassembly of the Manifold Block Assembly.



It is best to tighten the emergency gas valve and one-way valve with the manifold block body secured in a soft jawed vice.

NOTE

1. Before installing the emergency gas valve assembly, wrap the pipe threads with 2 ½ turns of Teflon® tape starting after the first thread. Apply the tape with slight tension to allow the tape to fill into the threads. Use only Teflon® tape. Hand tighten the valve, then continue an additional 1 ½ to 2 turns with a wrench keeping in mind the proper alignment of the control knob to the manifold body. Also, there should be at least one male thread visible. Check to be certain the valve is tight by trying to loosen the valve by hand.

It is NOT necessary to have the control knob for the emergency gas supply valve perfectly “square,” i.e., at a 90 degree angle to the side block. Any angle is acceptable provided that 1) the valve handle can be turned easily and 2) the diver can locate the handle easily.

DO NOT TIGHTEN THE VALVE BODY TIGHTER THAN NECESSARY! OVER TIGHTENING MAY OVERSTRESS THE PART AND CAUSE THE PART TO FAIL.

2. Next lightly lubricate the O-ring on the one-way valve and tighten into the manifold block assembly to 150 inch lbs. (17 Newton Meters)
3. Lightly lubricate O-rings and install on all port plugs.
4. Ensure that all supply hoses have been checked for damage and corrosion and that all hoses have O-rings which have been lightly lubricated.
5. Reinstall the backing plate. Install the screws and washers.
6. Reinstall all hoses and perform a test of the system. Test the emergency valve by attaching it to a bail out cylinder and first stage regulator with an intermediate air source no greater than 240 psi. There should be no leakage of air when the assembly is immersed in a tub of water. The one-way valve can also be tested at the same time. After the water test for leaks, while the system is still under pressure, blow dry the inlet to the one-way valve and then depressurize the system.

This page intentionally left blank



1430 Jason Way, Santa Maria, CA 93455
Phone: 805/928-7772 Fax: 805/928-0342
www.kirbymorgan.com E-mail: kmdsi@kirbymorgan.com