

Communications, Modular (excludes 17B, 17C, MK 21 and KMB BandMasks®)

Contents

COM-1	1.1 Daily Maintenance	COM-12	1.3.9.2 Communications Post Replacement
COM-2	1.2 Monthly Maintenance (or between jobs) (See Dive Lab Checklist A2.2)	COM-13	1.3.9.3 Installing the Microphone and Earphones
COM-3	1.3 Communications System	COM-14	1.4 Communications Module (New Design)
COM-3	1.3.1 General	COM-14	1.4.1 Removal Earphones and Microphone (WPC)
COM-3	1.3.2 Earphone Inspection	COM-16	1.4.2 Installation Earphone and Microphone (WPC)
COM-3	1.3.3 Removal of Communications Assembly	COM-17	1.4.3 Male Waterproof Connector Wires (MWPC)
COM-4	1.3.4 Replacement of Communications Assembly	COM-18	1.4.4 Inserting Strip Assembly Into Module Body
COM-5	1.3.5 Microphone Replacement	COM-19	1.4.5 Removal Earphones and Microphone (Post)
COM-5	1.3.6 Earphone Replacement	COM-20	1.4.6 Installation Earphone and Microphone (Post)
COM-6	1.3.6.1 Removing Earphone Speaker	COM-21	1.4.7 Post Connector Wires
COM-7	1.3.6.2 Installing Earphone Speaker	COM-22	1.4.8 Inserting Strip Assembly Into Module Body
COM-9	1.3.7 Waterproof Connector		
COM-9	1.3.7.1 Connector Removal		
COM-10	1.3.8 Connector Replacement		
COM-12	1.3.9 Communications Posts		
COM-12	1.3.9.1 Communications Post Removal		

1.1 Daily Maintenance

1. Remove the communications assembly from the helmet so it can dry completely. Remove the earphone covers from the earphones so they can dry completely. Clean the microphone with sanitizing solution, rinse it, and allow it to dry.



Uncover the earphones so they may dry.

1.2 Monthly Maintenance (or between jobs) (See Dive Lab Checklist A2.2)

If installed, visually inspect the earphones, microphone, wires, terminals, and communications posts. Test each component for proper operation. Connect to the deck amplifier and talk back and forth. Replace any defective earphones or microphone. Open the earphone rubber covers and remove the protectors. Allow to dry thoroughly. Replace defective earphones.



Good communications are vital to your safety. Regularly inspect the components of the communications

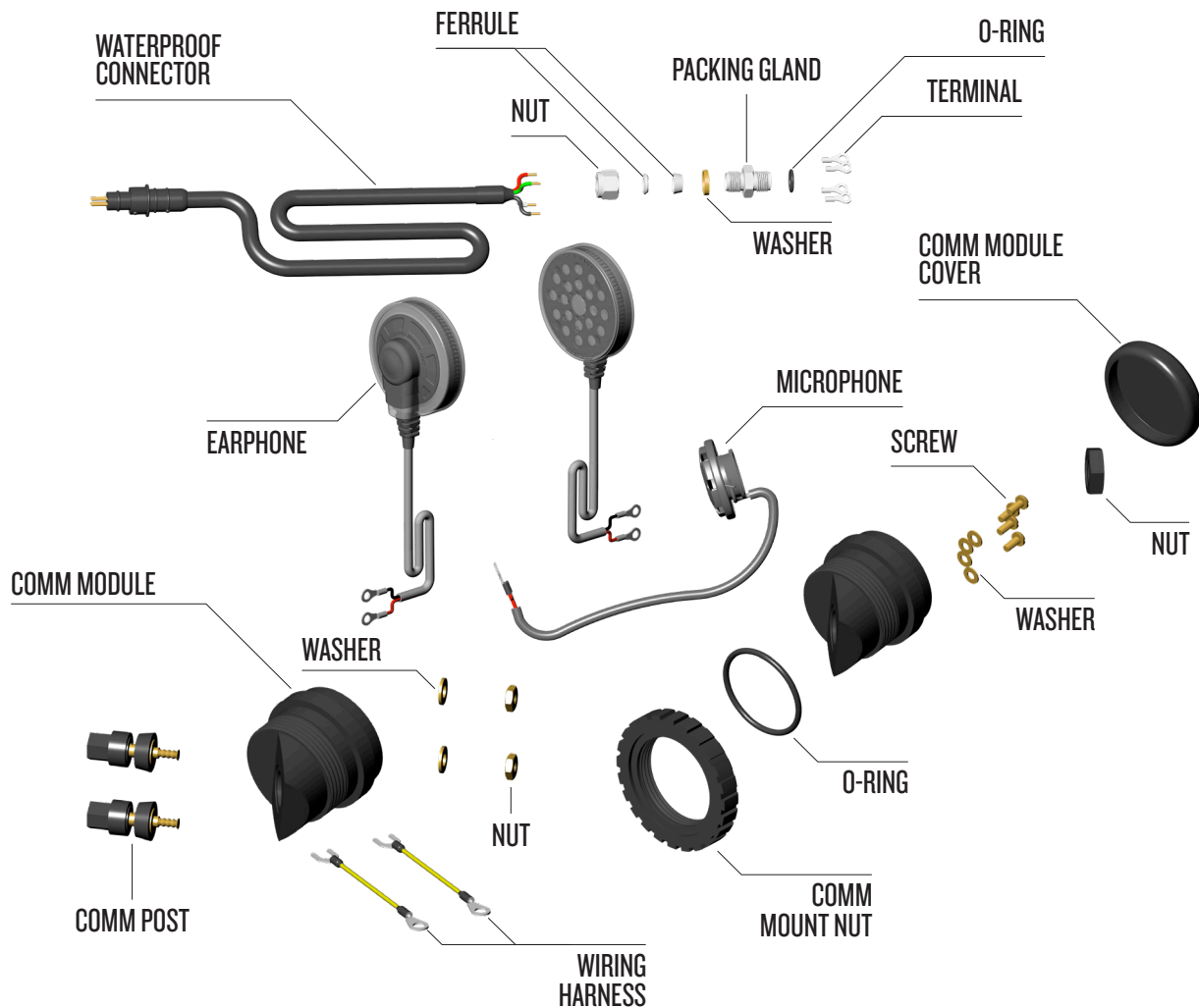

Components of the communications system (old design). See diagram "Components of the communications system (new design)." on page COM-15 for current design.

system and replace when necessary.

1.3 Communications System

1.3.1 General

The communications system in Kirby Morgan helmets requires regular attention and maintenance for proper function. Clear two way speech communications between the diver and the surface crew is one of the most important capabilities of surface supplied diving operations.

1.3.2 Earphone Inspection

To inspect the earphones, first remove the head cushion from the helmet. The earphones can be carefully pulled out of the retainers in the helmet shell for inspection and disassembly.

1. Remove the (clear) cover first and slide it along the wire to get it out of the way. Remove the earphone protector and then peel back the (black) rear cover.

If moisture is detected inside the covers, carefully check the speaker and dry the parts as needed.



Removing the rubber cover from the earphone.

2. Check the wire connections. They should be solid with no cuts, kinks, bends or cracks.

3. Check the mylar diaphragm. If the mylar is torn or loose, replace the entire unit, see "1.3.6 Earphone Replacement" on page COM-5.



Inspect the mylar earphone.

4. If the rubber covers are worn or damaged, replace them.

1.3.3 Removal of Communications Assembly

Tools required:

- None

The communications module and mount nut should be checked daily for proper installation and tightness. The best way to check is by simply loosening the mount nut by hand (Counter clockwise $\frac{1}{8}$ to $\frac{1}{4}$ turn) then retightening by hand. The module does not need to be tightened excessively to maintain a proper seal.



NOTE

Excessive torque may cause part failure.

The entire communications assembly can be replaced as follows:

1. Slide the earphones out of the retainers.



Remove the earphones from the earphone retainers.

2. Pull the microphone out of the oral nasal mask.



The microphone must be removed from the oral nasal mask.

3. Unscrew the communication mount nut on the outside of the helmet shell.



The large plastic communication nut is removed from the communications module.

4. Push the communications module into the helmet shell interior. Remove the O-ring.

5. The entire communications assembly can be replaced with a spare assembly for the most rapid turnaround.

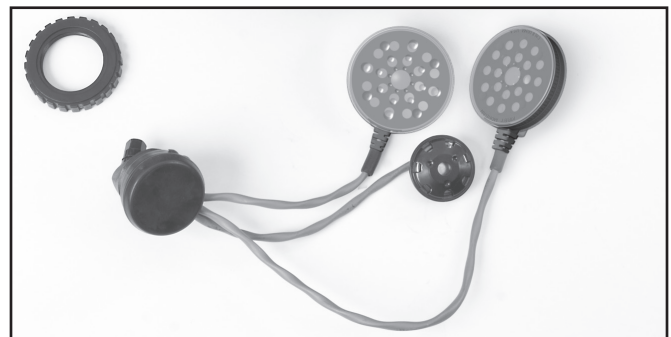

The modular communications system can be rapidly replaced.

1.3.4 Replacement of Communications Assembly

1. Install the O-ring onto the communications module.

2. Carefully push the communications module through the opening in the helmet shell. The communications posts, or waterproof connector

assembly if present, should be pointed toward the rear of the helmet.

3. Screw the communication mount nut onto the communications module. Tighten by hand until snug against the helmet. NEVER use a wrench to tighten this part.

⚠ WARNING

The communication mount nut should never be tightened using a spanner or other tool. Tightening the mount nut using a tool will add excessive strain to the parts and could cause damage to the module allowing the module to break free, resulting in flooding of the helmet which could cause injury or drowning.



The mount nut must be securely fastened to hold the communications module in position. Hand tighten only.

4. Place the earphones into the earphone retainers.

5. Route the earphone wires so they do not obscure the diver's vision. The wire for the left speaker is tucked into the space between the bottom of the oral nasal mask and the helmet shell.

1.3.5 Microphone Replacement

Tools required:

- 1/8 inch Flat Blade Attachment on Torque Screwdriver
- Tie Wrap Cutter

The entire microphone is replaced the same as the earphones by removing the wire lugs from the communications module and replacing the entire unit.

1. Remove the entire communications assembly as per "1.3.3 Removal of Communications Assembly" on page COM-3.

2. Remove the rubber cover.

3. Remove the screws and washers from the communications module.

4. Lift the terminal lugs out of the communications module. **Note the position of the terminal wires.**

5. Install the terminals for the replacement microphone. Note that the wires must go on separate terminals, just as before.

6. Install the microphone into the oral nasal mask.



Install the microphone into the oral nasal mask.

1.3.6 Earphone Replacement



NOTE

If only the earphone speaker is damaged, it can be replaced by removing the tie-wrap inside of the covers, unscrewing the wire connection and replacing the necessary components. There is no need to completely remove the assembly from the communications module.

When handling the earphone speaker take special care of the FRONT as this side is more delicate than the back and damage can occur if handled improperly.



FRONT

BACK

Tools required:

- #1 Phillips Head Screwdriver

1.3.6.1 Removing Earphone Speaker

1. Remove the clear (front) earphone cover and slide it down the communication wire and away from the earphone speaker.



Earphone protector should fall away from earphone speaker as it is captured by the cover and held in place.



2. Remove the black (back) earphone cover and slide it down the communication wire and away from the earphone speaker.



3. Cut the tie wrap that secures the wire assembly to earphone.



4. Using #1 Phillips screwdriver, loosen set screws.

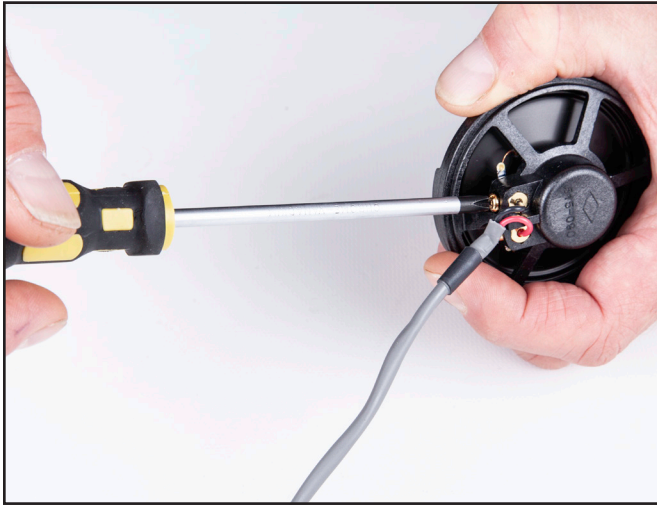

5. Pull both black and red wires out and away from Earphone Speaker.

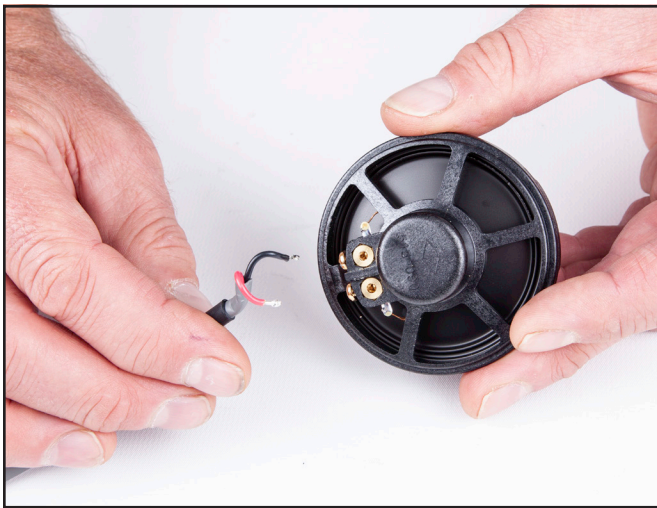

1.3.6.2 Installing Earphone Speaker

Verify that the earphone cover set is in place on the communication wire.



1. Unscrew the set screws from the terminals found on the earphone speaker two to three turns.



The set screws will have to be backed out far enough to allow the wires to enter the terminal without restriction. If screws are installed unscrew just enough to get the wires in the terminals.



2. Put the red lead wire into the right terminal and tighten screw.



3. Put the black lead wire into the left terminal and tighten screw.

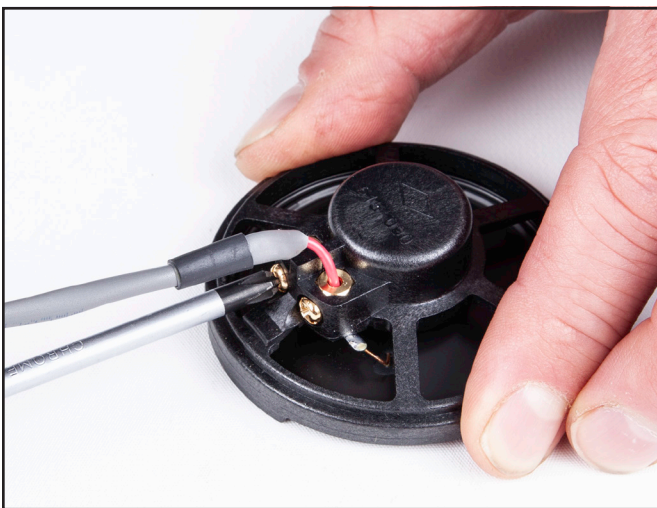
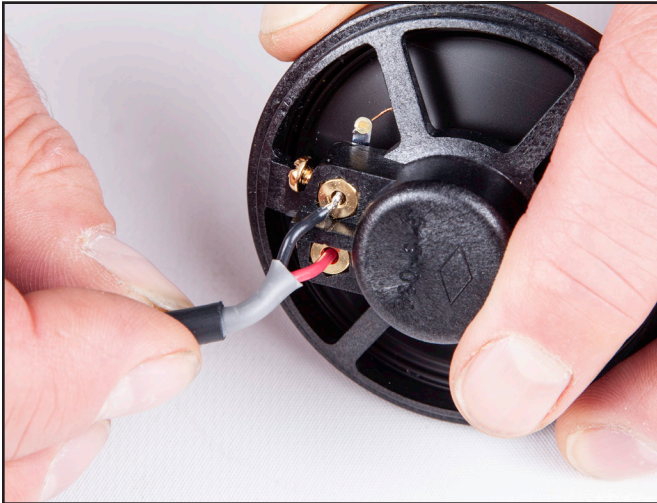

4. Use tie wrap P/N 520-038 to secure communication wire to earphone speaker. Be sure to loop tie wrap onto the gray jacket of the cable. Tie wrap should not touch black or red wire.



Tie wrap head should face to the side or away from the backside of the speaker.

NOTE

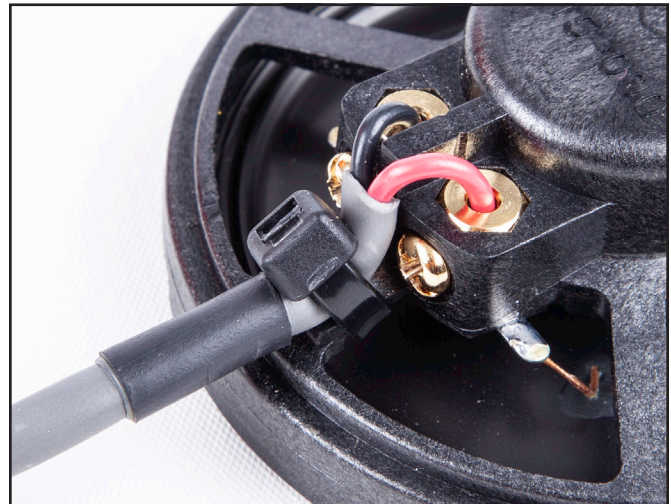

5. Cut the excess from the tie wrap and replace cover set and earphone protector.





6. Test for proper function.

1.3.7 Waterproof Connector

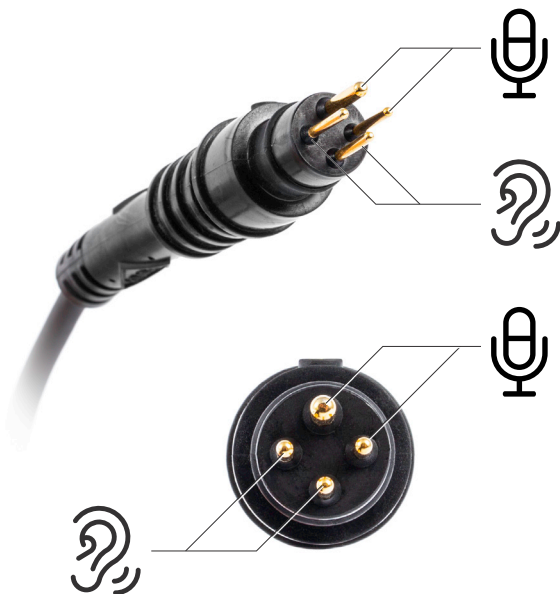

Almost all Kirby Morgan helmets are supplied with modular communications that have either a waterproof connector or bare wire posts. The waterproof connector is subject to failure if the helmet receives rough handling. To replace the connector use the following procedure.

1.3.7.1 Connector Removal

Tools required:

- 3/4 inch Open End Wrench
- 1/8 inch Flat Blade Attachment on Torque Screwdriver

1. Remove the communications assembly from

the helmet as per "1.3.3 Removal of Communications Assembly" on page COM-3.

2. Remove the rubber cover.

3. Remove the screws and washers from the communications module.



4. Remove the earphone and microphone wire terminals from the interior of the communications module.

5. Use a 3/4 inch wrench to unscrew the waterproof connector from the communications module.



Use a 3/4 inch wrench to unscrew the waterproof connector.

6. Pull the connector through the module.

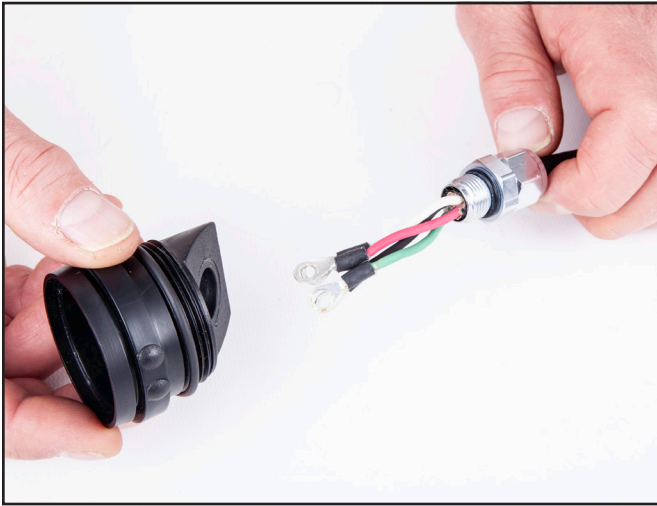

Pull the connector out of the module.



3. Using a 3/4 inch wrench, tighten the waterproof connector.

1.3.8 Connector Replacement

1. Insert the new waterproof connector assembly into the communications module.
2. Screw the waterproof connector into the nut. Tighten until snug.

Male 4 pin numbering is in a counter clockwise direction

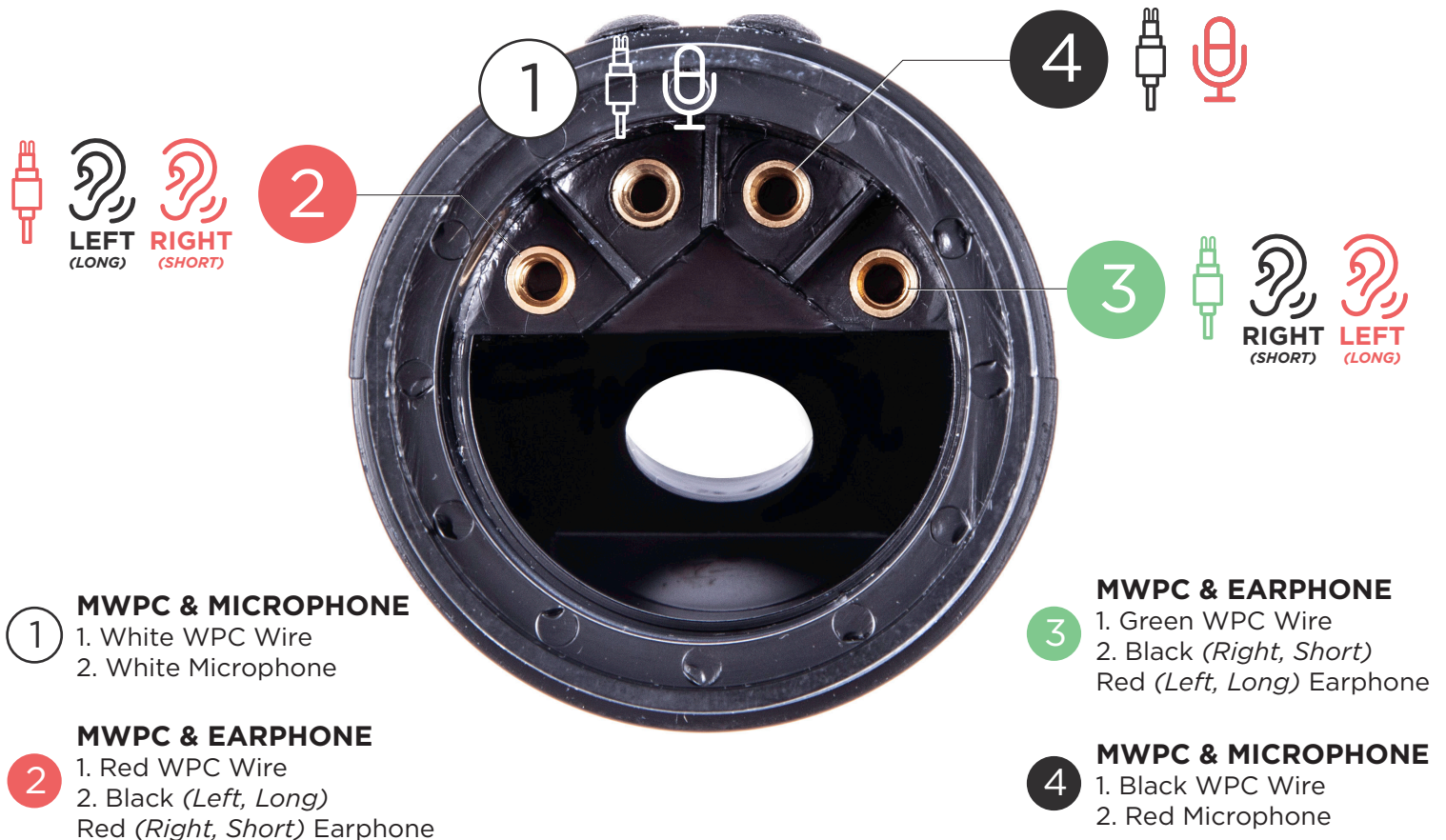



4. Place the waterproof connector wires on the connector.

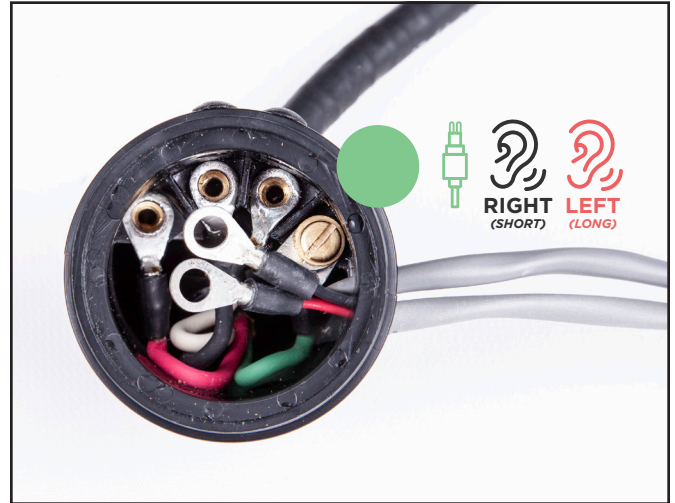

7. Using the washer and screw, install the black wire from the left (*long*) earphone and the red wire from the right (*short*) earphone.

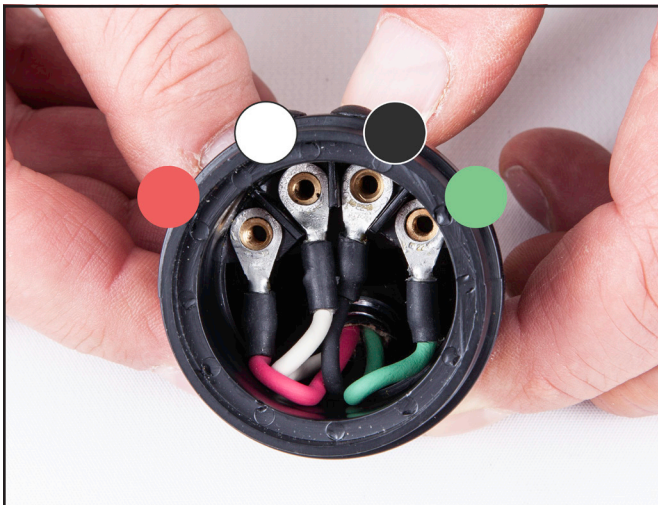

5. Insert the earphone wires back into the module.

6. Using the washer and screw, install the black wire from the right (*short*) earphone and the red wire from the left (*long*) earphone.

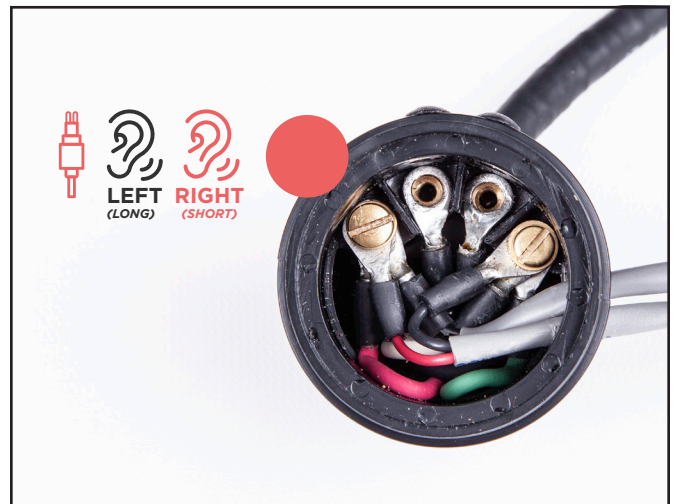

8. Insert the microphone wires into the module.

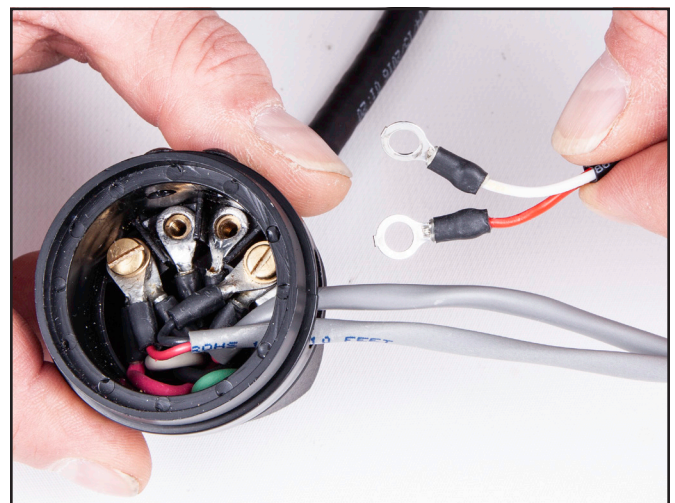

9. Using the washer and screw, install the red and white microphone wires to the module.

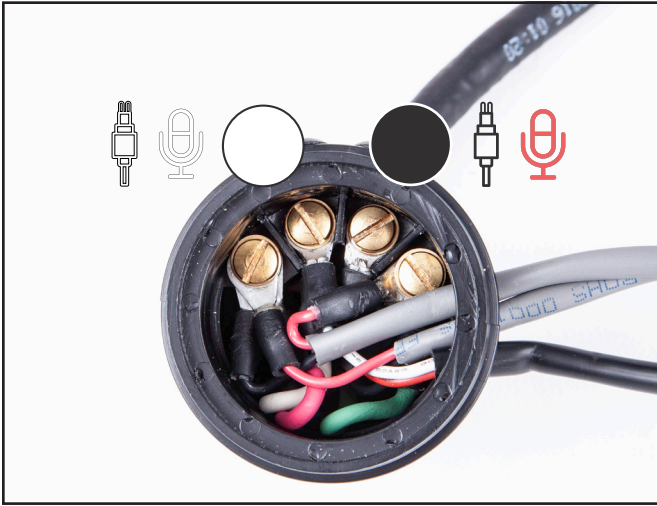

10. Slide the O-ring down the waterproof connector wire and install over the communications module.



11. Install the rubber cover.



1.3.9 Communications Posts

1.3.9.1 Communications Post Removal

Tools required:

- Flat Blade Screwdriver
- 3/32 inch Punch or Small Drill Bit

COMM MODULE

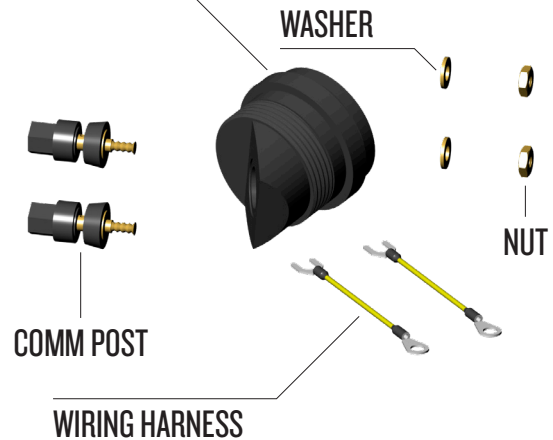

1. Remove the communications assembly from the helmet as per "1.3.3 Removal of Communications Assembly" on page COM-3.

2. Remove the rubber cover.

3. Remove the right and left screws and washers from the communications module.

4. Remove the earphone and microphone wire lugs from the communications module.

5. Remove the communications posts from the module by inserting a 3/32 inch punch or similar tool into the terminals found on the metal posts and turn counter clockwise.

6. Remove all traces of silicone sealant from the communications module and posts.

1.3.9.2 Communications Post Replacement

1. Apply a small amount of fresh RTV (silicone sealant) to the base of the communications posts.



⚠ CAUTION



Use good ventilation when using RTV sealant. Fumes from this material may irritate your lungs. Read and follow the directions in the MSDS before using this material.

⚠ CAUTION



Wear eye protection when using RTV sealant. This material may irritate your eyes. Read and follow the directions in the MSDS before using this material.

⚠ CAUTION



Wear hand protection when using RTV sealant. This material may irritate your skin. Read and follow the directions in the MSDS before using this material.

2. Insert the communications posts into the module.

3. Place washer and nut onto post just to engage the threads one to two complete turns.

4. Insert wiring harness between washer and nut and tighten until snug. Do not overtighten.



Use a wrench and $\frac{3}{32}$ punch or small drill bit to tighten the communication post nuts.

5. Repeat above steps for remaining post.



Line up the holes in the metal posts.

NOTE

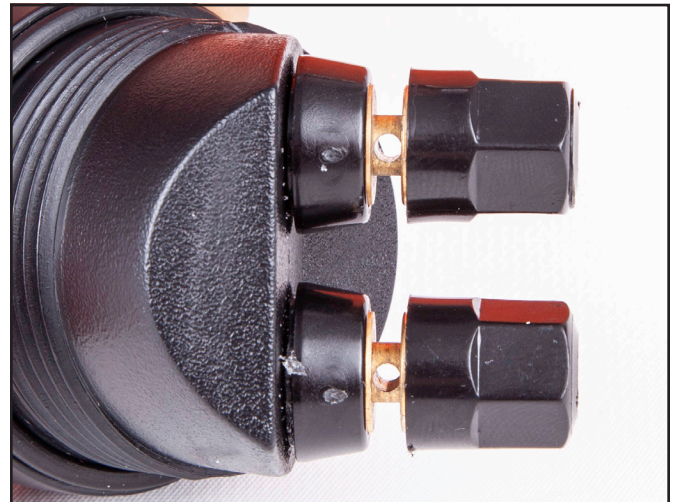

1.3.9.3 Installing the Microphone and Earphones



Nothing is attached to the two center screws.

NOTE

In two wire communication the two wire lugs from each individual element are separated and secured to the **two outer screw terminals** in the communications module.

1. On the left screw terminal attach one black and one red earphone wire from opposite earphones and the white microphone wire.

2. On the right screw terminal attach one black and one red earphone wire from opposite earphones and the red microphone wire.

1.4 Communications Module (New Design)

The new communications body has thicker walls adding to the strength of the module as well as a removable strip assembly. This removable strip assembly allows all wire terminals to be inspected and serviced out and away from the inside of the communications module.

OLD MWPC



NEW MWPC

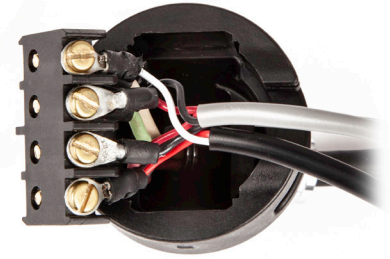

By removing the terminal wires from the umbilical side, the strip assembly can be separated from the module body, but is not required to be removed for installing or removing the microphone or earphones assemblies.

1.4.1 Removal Earphones and Microphone (WPC)

Tools required:

- Flat Blade Screwdriver



A

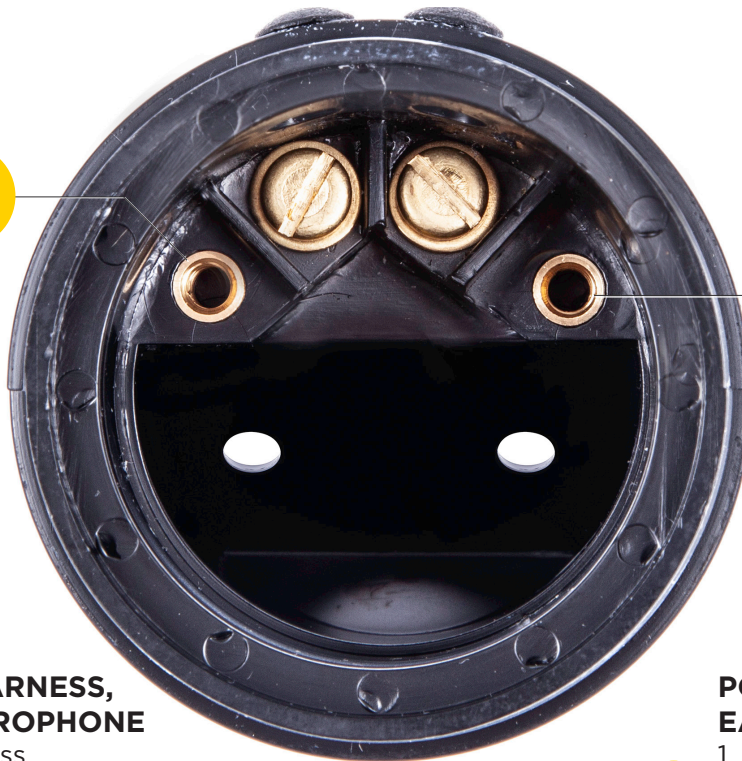

B



POSTS WIRING HARNESS, EARPHONE & MICROPHONE

1. Posts Wiring Harness
2. Black (Left, Long) Red (Right, Short) Earphone
3. White Microphone

POSTS WIRING HARNESS, EARPHONE & MICROPHONE

1. Posts Wiring Harness
2. Black (Right, Short) Red (Left, Long) Earphone
3. Red Microphone

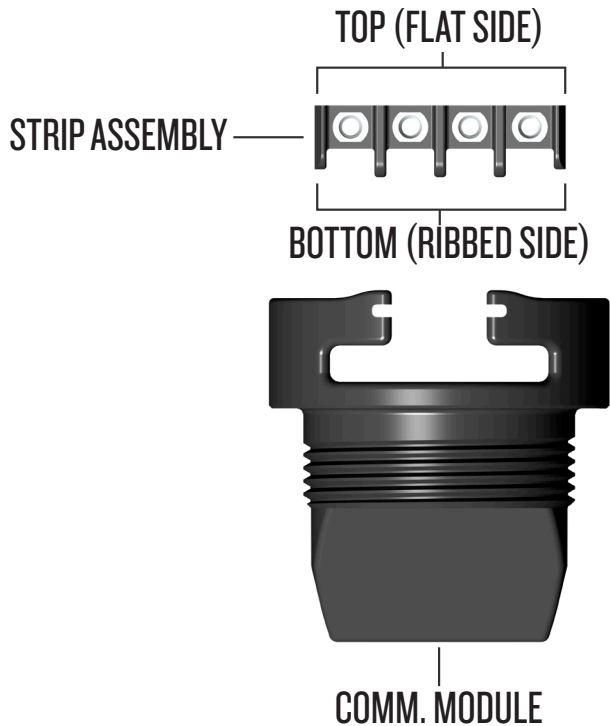

"1.3.3 Removal of Communications Assembly" on page COM-3.

1. Slide the strip retainer plate out of the communications module body.

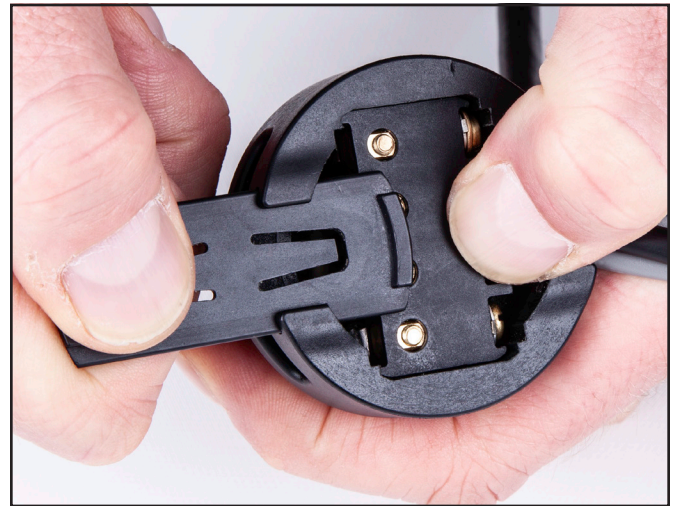

To remove the communication assembly from the helmet, reference the KMDSI modular manual



NOTE

The strip retainer plate will slide to the left or right side of the module. Once one side of the strip retainer plate is free from the module body, additional down pressure on the strip assembly might be required.

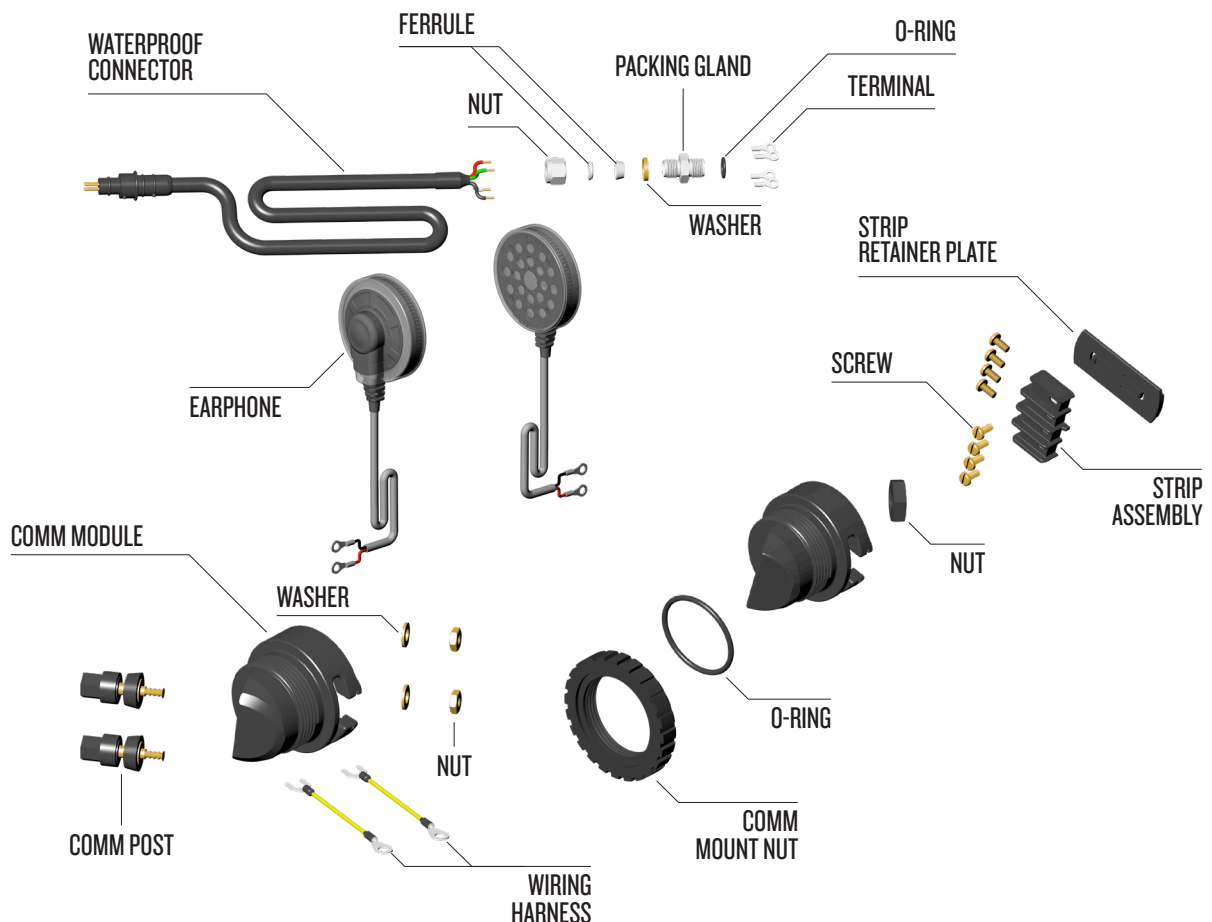

Components of the communications system (new design).

2. Lift the strip assembly out of the body.

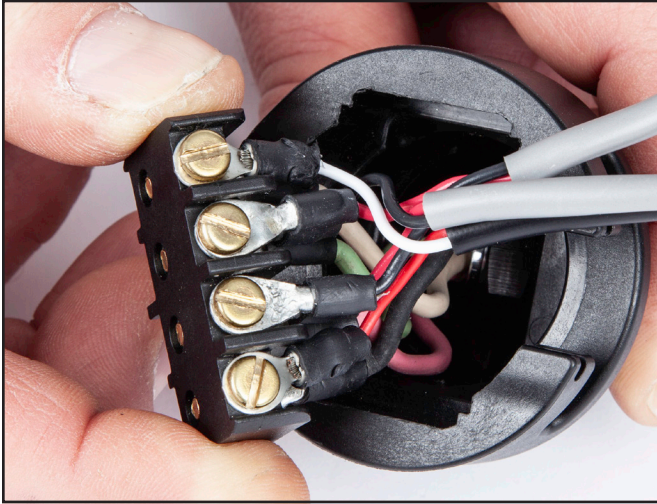

3. Remove the screws then the earphone/microphone assembly wires. **Note the position and orientation of the wires for reinstallation.**

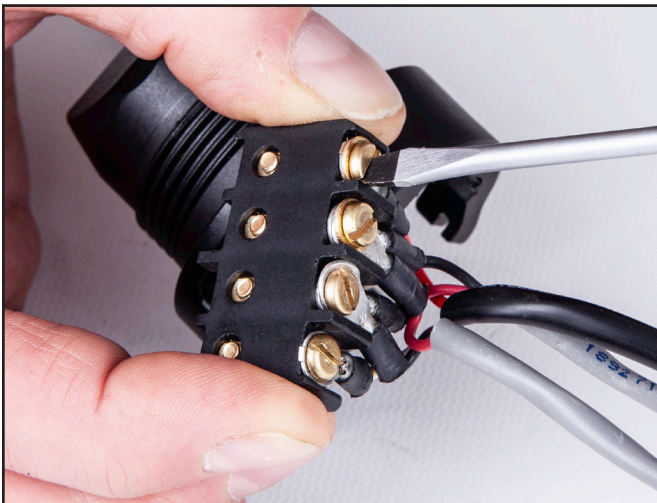

1.4.2 Installation Earphone and Microphone (WPC)

Tools required:

- Flat Blade Screwdriver



Strip Assembly can be either attached or removed from the communications module.

NOTE

Earphones are secured to the two center holes.

Microphone wires are attached to the two outer holes on the strip assembly.

1. Attach one black and one red earphone wire

from opposite earphones to each of the center holes.

2. Center the terminals into the correct slots and secure with a screw.

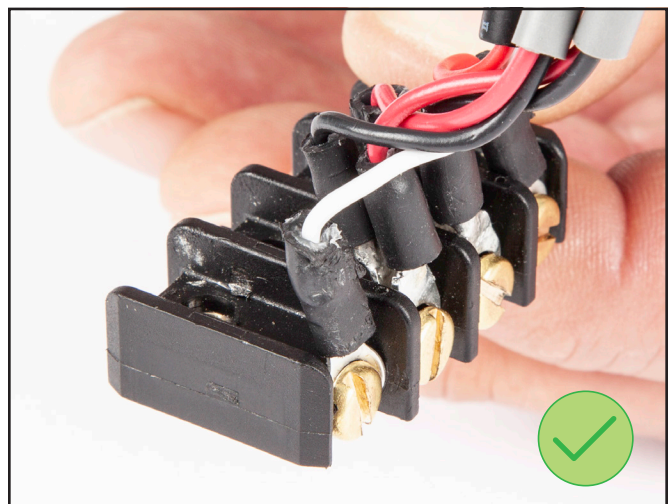
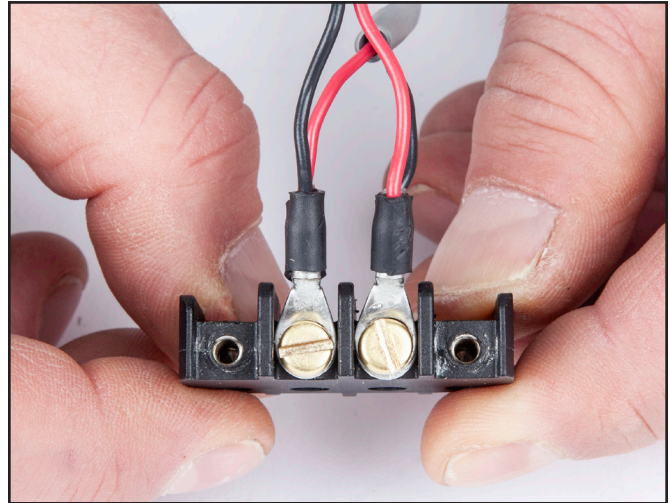

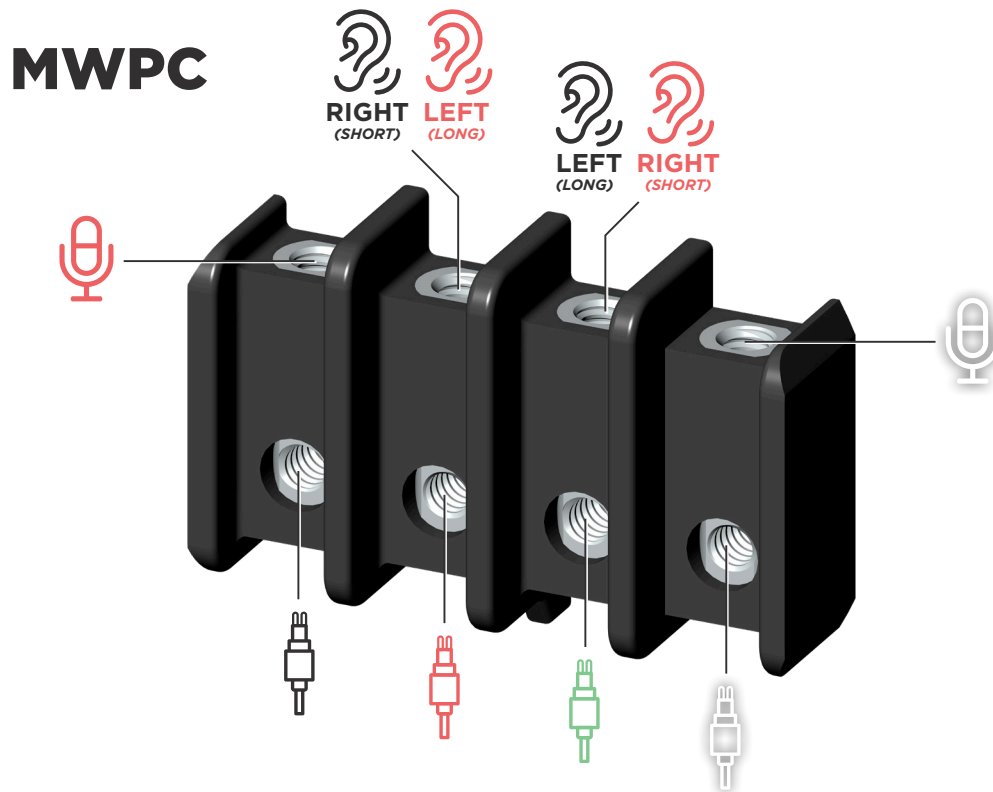

NOTE

Refer to the KMDSI wiring diagram.

3. Secure white microphone wire on the same side as the white MWPC wire on the strip assembly.



NOTE

With the ribbed side facing up and the MWPC screw holes on the left side, the white microphone wire will be attached to the lower right side of the strip assembly.

4. Secure Red microphone wire on the same side as the black WPC wire.

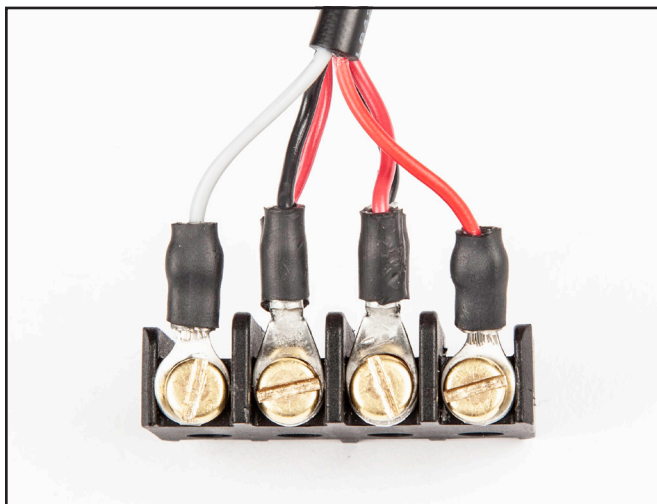

1.4.3 Male Waterproof Connector Wires (MWPC)

With the smooth side of the strip assembly facing down, the four waterproof connector wires will be secured to the screw holes that are facing up on the strip assembly.

1. Position the strip assembly so the ribs are facing up and the top (flat) side is down.

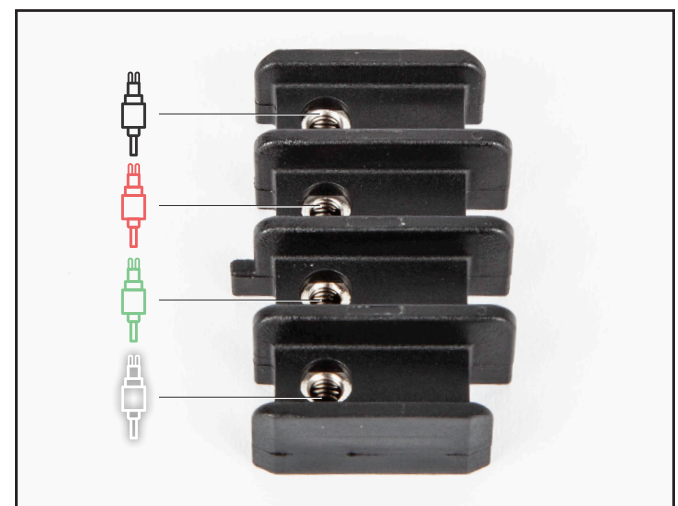

2. Insert the four waterproof connector wire terminals into the correct slots and secure with screws. Refer to the MWPC four wire diagram.

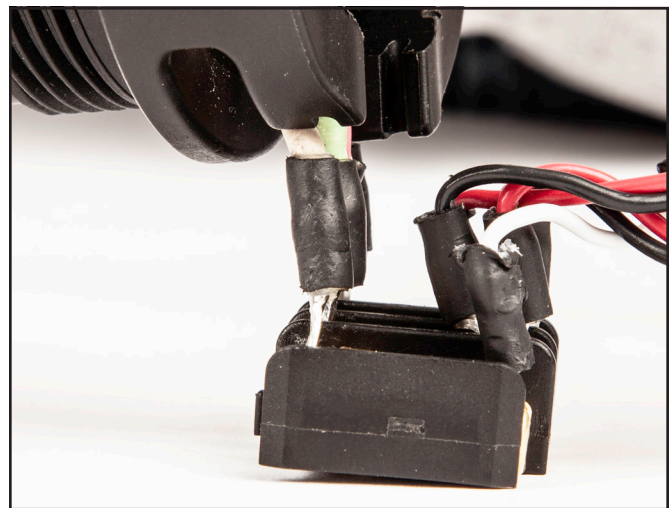
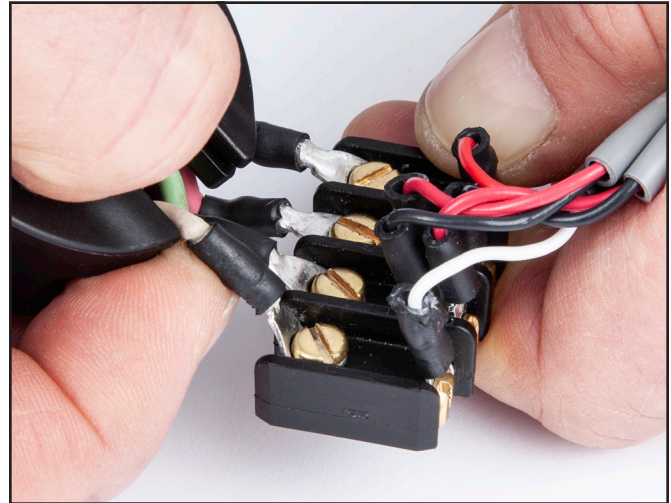

1.4.4 Inserting Strip Assembly Into Module Body

1. With the top of the strip assembly facing up, position earphone/microphone wires through exit slot of communications module.



NOTE

A loop will form where the wires go down into the communications module and then back up and out of the exit slot on the communications body.

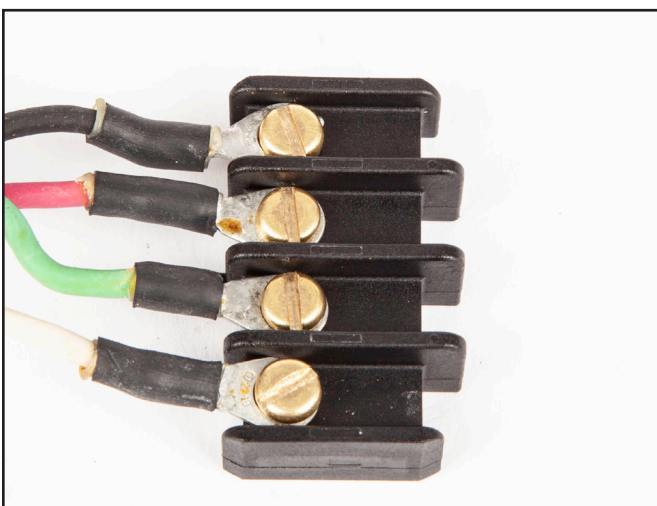

3. Bend the MWPC wire terminals up, so that they are at a 90 degree angle to the strip assembly.



2. The earphone/microphone terminals will have to be pushed in slightly to allow wires to properly exit the module body.



3. Push down on the strip assembly and slide the strip retainer plate through the receiving slots.

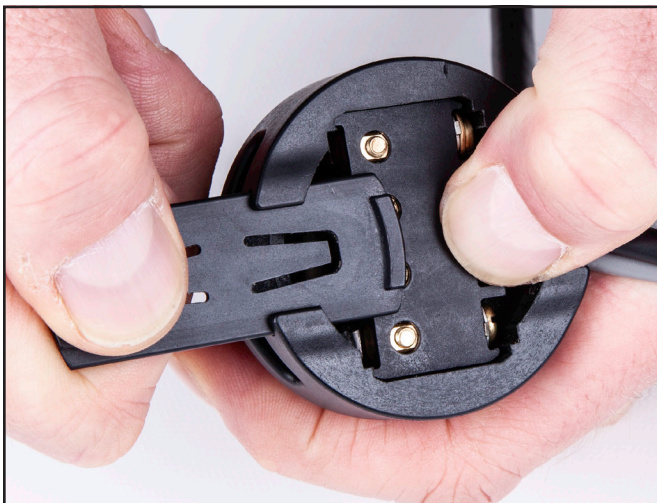

NOTE

There is a top and a bottom to the strip retainer plate. The raised edges indicate the top. Once one side of the plate is inserted into the module body, additional down pressure on the assembly and plate might be required.

1.4.5 Removal Earphones and Microphone (Post)

Tools required:

- Flat Blade Screwdriver

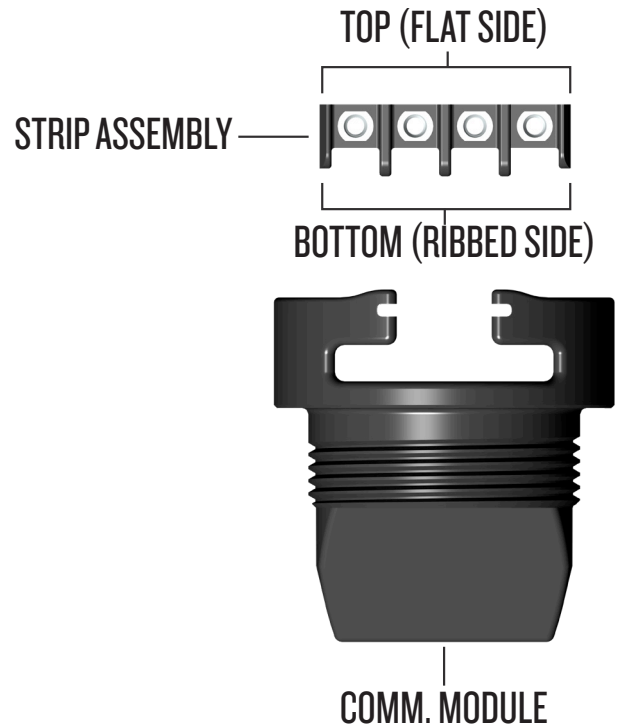

To remove the communication assembly from the helmet, reference the KMDSI modular manual "1.3.3 Removal of Communications Assembly" on page COM-3.

1. Slide the strip retainer plate out of the communications module body.

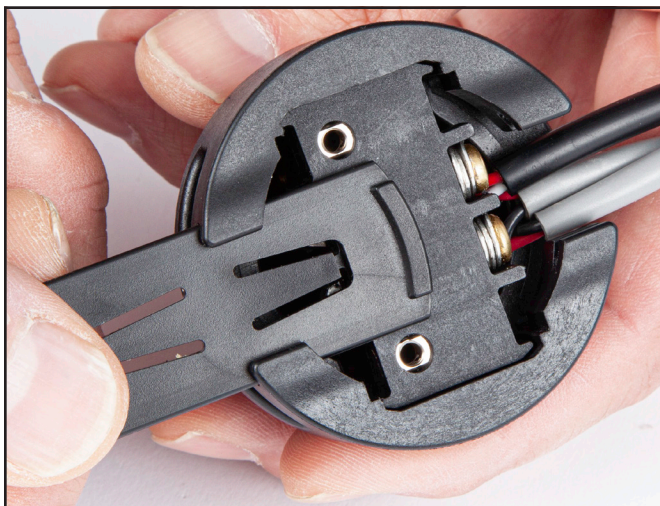

2. Lift the strip assembly out of the communications module body.

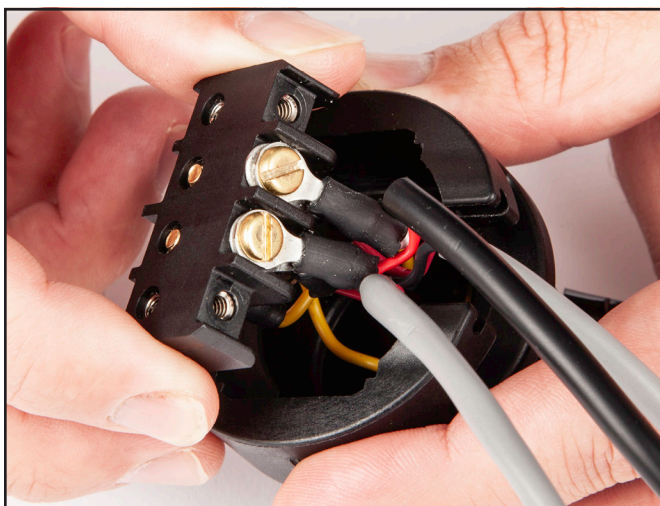

3. Remove the screws and the earphone/microphone assembly wires.

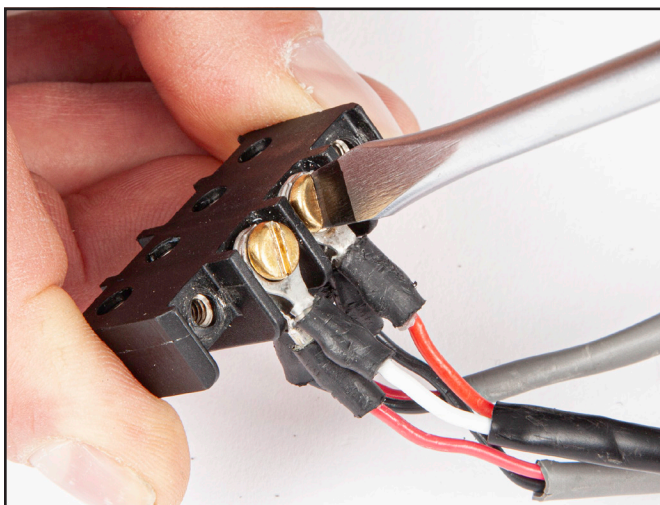

Note the position and orientation of the wires for reinstallation.

1.4.6 Installation Earphone and Microphone (Post)

Tools required:

- Flat Blade Screwdriver



NOTE

Three wire terminals will be secured to each of the two center holes found on the side of the strip assembly.

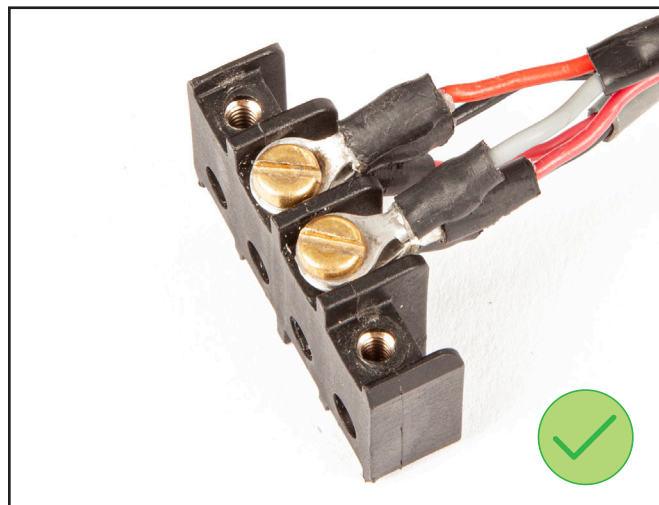
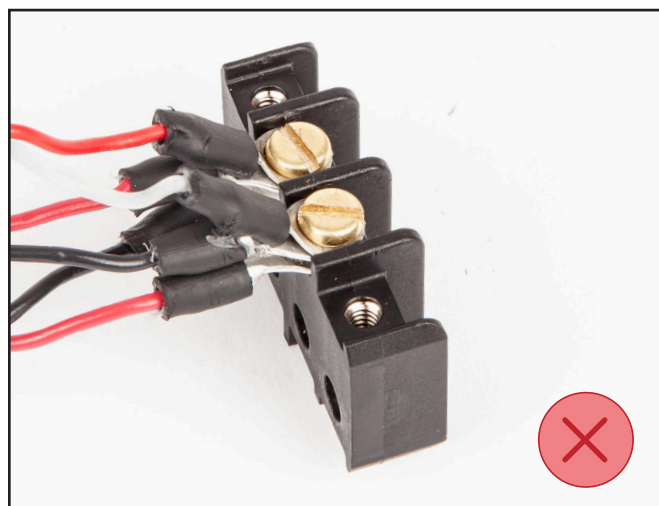

1. Pair one black and one red wire from different earphones.

Two Wire Posts

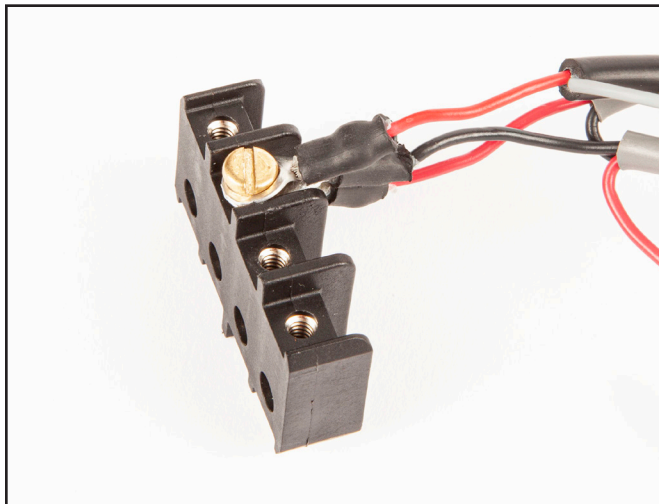
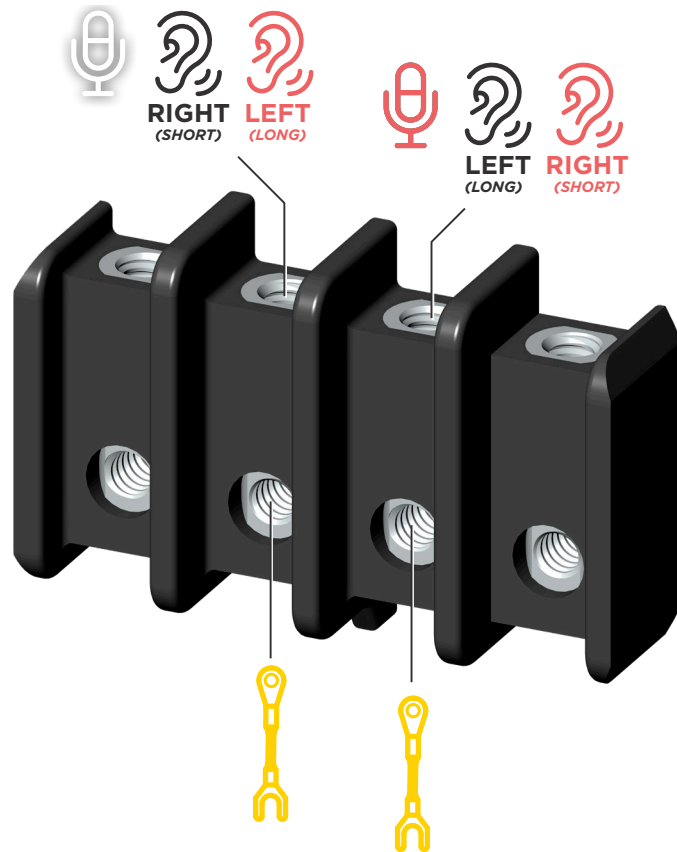

2. Now add one terminal from the microphone so three terminals are stacked on top of each other.



Recommended orientation is with earphone terminals touching the strip assembly first and microphone terminal touching the screw.

3. Secure terminals to one of the two center holes found on strip assembly.

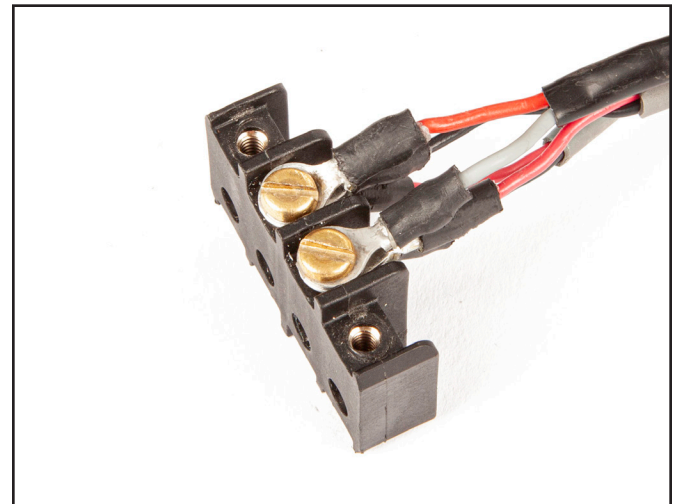

If the strip assembly is removed from the module body use the TOP (flat) side of the strip assembly for orientation.

With the flat side facing up the earphone and microphone terminals are secured to the two center holes found on the side of the strip assembly.

1.4.7 Post Connector Wires

1. Position the strip assembly with the **TOP (flat) side** of the strip assembly **down** and the **BOTTOM (ribbed) side** facing **up**.

2. Secure the two wire post terminals to the two center holes.



3. Bend terminals down 90 degrees away from strip assembly.

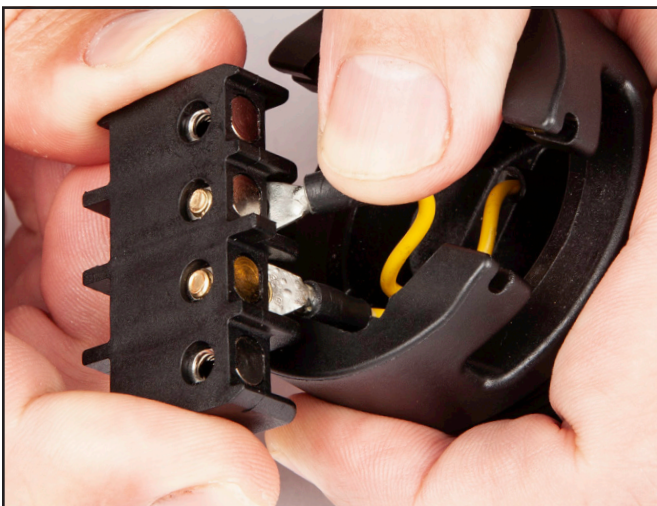

1.4.8 Inserting Strip Assembly Into Module Body

1. With the TOP (flat) side of the strip assembly facing up, position earphone/microphone wires through exit slot of communications module.

2. The earphone/microphone terminals will have to be pushed inward to allow the strip and connected wires to drop into the module body properly.



NOTE

A loop will form where the wires go down into the communications module and then back up and out of the exit slot on the communications body.



3. Push down on the strip assembly and slide the strip retainer plate through the receiving slots.

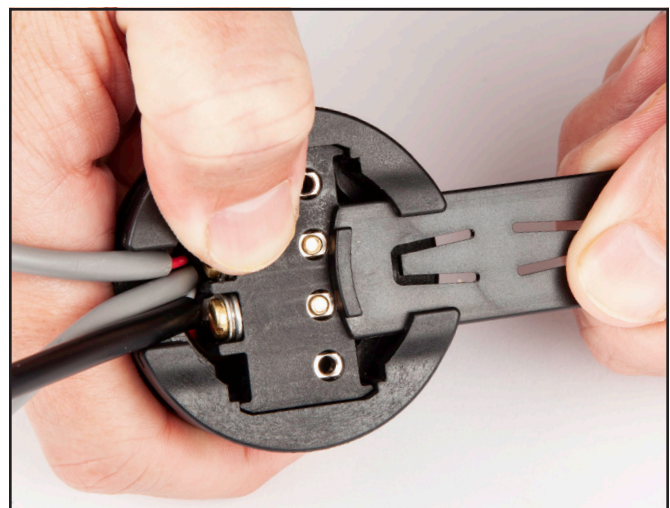

NOTE

There is a top and a bottom to the strip retainer plate. The raised edges indicate the top. Once one side of the plate is inserted into the module body, additional down pressure on the assembly and plate might be required.