

# Stainless Steel Helmets with REX Pod

## Contents

### REXPOD-1 1.1 REX® Pod System

REXPOD-1	1.1.1 REX® Pod System and Regulator Removal
REXPOD-4	1.1.2 Removal of Regulator Alone

## 1.1 REX® Pod System

### 1.1.1 REX® Pod System and Regulator Removal

The stainless steel helmets use a unique pod system. The pod is designed to serve as the mounting point for the regulator. Under normal conditions, it is not necessary to remove the pod to service the regulator.



#### NOTE

There are two different length pod mounting screws; six short screws and two longer screws. Also, the two bottom screw heads are positioned on the inside of the helmet shell, while others are on the outside.

The regulator exhaust and exhaust valve in the pod are made of high grade silicone. The regulator and pod exhaust are very durable and resilient, however they should be replaced at least once a year or whenever inspection reveals any signs of damage or deterioration.

All O-rings should be replaced at least once a year or whenever damage/deterioration is present or suspected. In order to replace the pod exhaust valve, the demand regulator must be removed from the helmet. Removing the regulator is not difficult if these instructions are followed.

The regulator can be removed without removing the pod. However, during overhauls the pod should be removed for inspection and gasket replacement.

#### Tools required:

- Regulator Mount Nut Tool P/N 325-640 (in Tool Kit P/N 525-768 Included with Helmet)
- $\frac{3}{8}$ " Ratchet Extension with Driver
- $\frac{1}{4}$ " Flat Blade Screwdriver
- #1 Phillips Screwdriver

### REXPOD-4 1.2 Reinstalling the Pod on the Helmet

### REXPOD-6 1.3 Reinstalling the Regulator on the Helmet

- $\frac{3}{8}$ " Nut Driver or  $\frac{3}{8}$ " Open End Wrench
- $\frac{5}{32}$ " Hex Key (Ball End is Helpful)
- $1\frac{1}{16}$ " Open End Wrench
- Two  $1\frac{3}{16}$ " Open End Wrench or Back Up Wrenches P/N 540-551 & 540-550 (In Tool Kit P/N 525-768 Included with Helmet)

1. Remove the chin strap by removing the screws that secure it.



*To remove the pod, start by removing the chin strap.*

2. Remove the two snap tabs adjacent to the swing catch assembly.

3. Remove the screws that secure the whisker to the port retainer. Take care not to lose the whisker spacers, or the zinc anodes. If the helmet has no anodes (standard on stainless steel helmets since late 2012) it will have kidney plates on the whiskers.



*Remove the screws that secure the zinc anodes, whisker spacers and whiskers.*

4. Remove the bent tube assembly as per "1.2.1 Removal of the Bent Tube Assembly" on page BNT-1.

5. Remove the nose block device as per "1.2.1 Nose Block Assembly Removal" on page FCPRT-6.



*Protect the nose block device knob with a plastic cap or rag when you remove it.*

6. Remove the communication module from the helmet per "1.3.3 Removal of Communications Assembly" on page COM-3.

7. Remove the oral nasal mask by pulling it off the regulator mount nut.

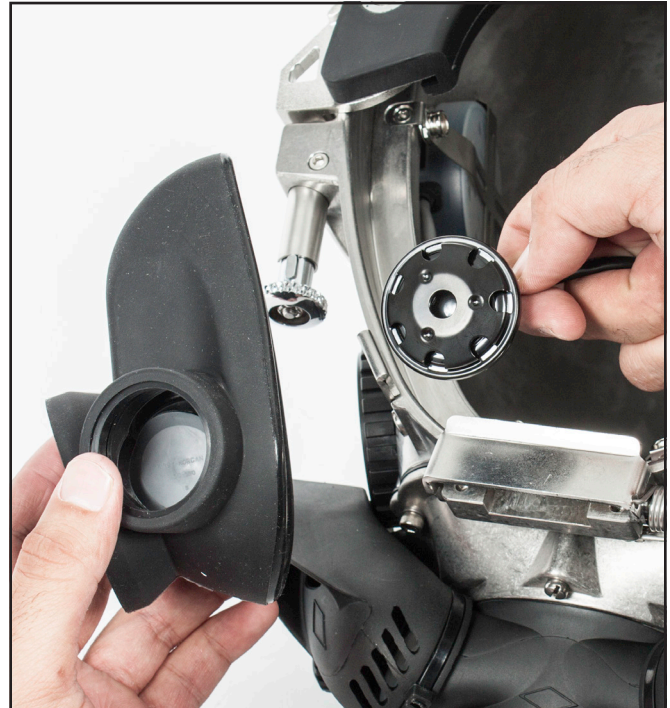

*Remove the nose block device, microphone, and oral nasal mask.*

8. Loosen the screws gradually in a staggered pattern. This is much easier to do if you loosen the regulator mount nut so that the regulator is free to turn.



*Loosen the regulator mount nut to make it easier to remove the pod.*



NOTE That the two longest screws secure the nuts (and pod) just below the face port.



NOTE That the bottom two nuts attach on the exterior of the pod, while the remaining nuts attach on the interior of the pod.

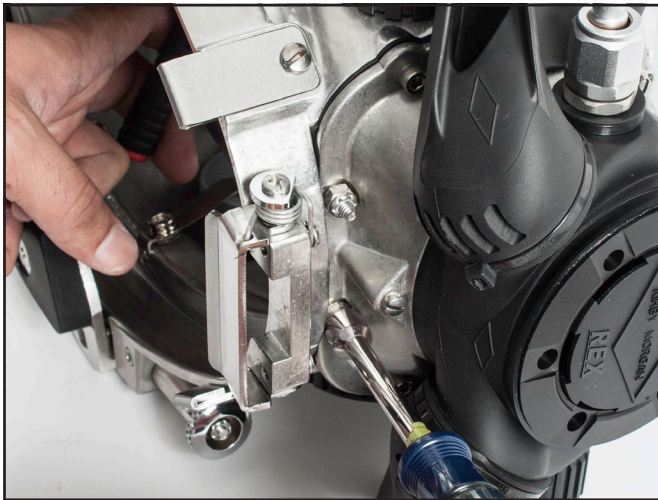

Bottom nuts on the exterior of the pod.

9. Separate the pod/regulator assembly from the helmet assembly.



Separate the pod/regulator assembly from the helmet shell.

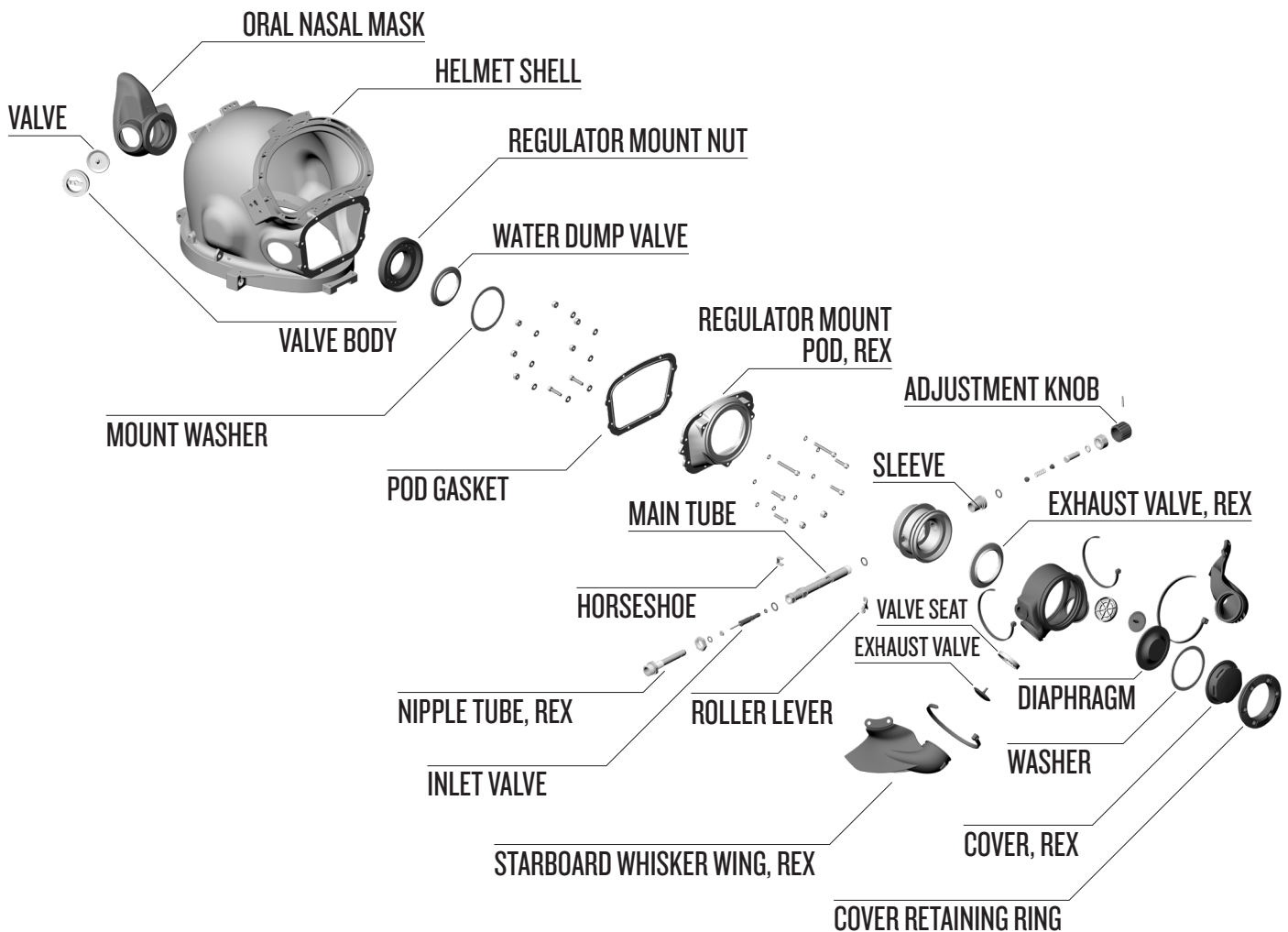

Blowpart of REX® Pod and oral nasal mask.

10. Remove the gasket for cleaning or replacement.



*Remove the gasket for cleaning or replacement. Note the ridge on the gasket. This ridge is designed to help maintain the proper position of the gasket in the groove in the pod.*



*Removal of the regulator mount nut.*

11. The lock nuts may be reused, once. Be sure to replace them upon the next pod gasket inspection. Failure to replace with the second maintenance could result in an improper seal of the pod, or loosening of the fasteners.

### 1.1.2 Removal of Regulator Alone

In most circumstances, it is not essential to remove the pod if you need to service the regulator. To remove the regulator by itself, use the following procedure.

1. Remove the bent tube assembly. See "1.2.1 Removal of the Bent Tube Assembly" on page BNT-1 for the proper procedure.

2. Remove the screws that secure the whisker to the port. Take care not to lose the zinc anodes, screws, whisker spacers or kidney plates if present.



*Take care not to lose the whisker spacers.*

3. Remove the oral nasal mask following the procedure in "1.7.1 Oral Nasal Mask Removal" on page REX-15.

4. Loosen the regulator mount nut.



**NOTE**

The nut cannot be removed with any of the regulator mounting threads engaged. The regulator should be pulled from the pod as the mount nut is being loosened.

5. Pull the regulator body away from the helmet.

## 1.2 Reinstalling the Pod on the Helmet

### Tools required:

- $\frac{3}{8}$ " Nut Driver or  $\frac{3}{8}$ " Open End Wrench
- $\frac{5}{32}$ " Hex Key (Ball End is Helpful)

1. Install the gasket on the pod. Make sure that the ridge on the gasket is properly seated in the groove in the pod.

2. Install all of the allen screws and washers

through the pod and gasket, with the exception of the bottom two. The screws will help to align the pod and gasket to the helmet.



**NOTE**

Thread all of these screws through the gasket slowly so as not to damage the holes in the gasket with possible sharp edges of the thread. These holes have small sealing rings molded around them to seal the threads to the holes in the metal parts. It is recommended to thread the screws through the gasket rather than push it through.

Remember that the two long screws are installed in the top two holes of the pod, between the top of the regulator cover and the port retainer.

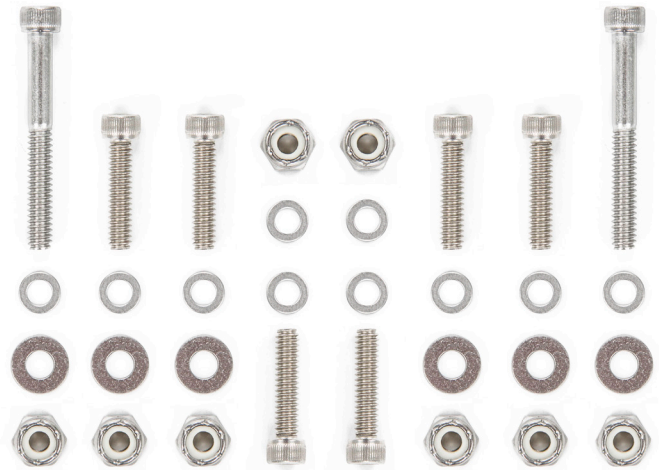

**NOTE**

The two longest screws are inserted into the top two holes of the pod. The two bottom screws are secured in the opposite orientation (lock nuts are on the outside of the pod) and both washers are thinner.

3. Mate the pod to the helmet shell.

4. Install the remaining two bottom screws, washers and nuts. Run the nuts up until they are finger tight. The nuts are positioned on the outside of the pod on the two screws on the bottom, below the regulator.

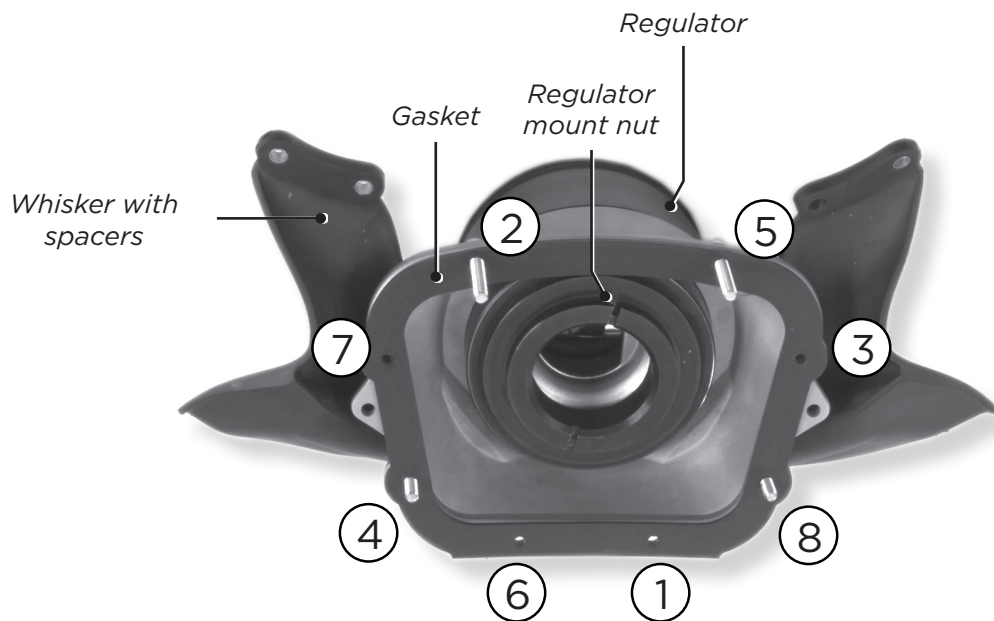

*This photo shows the pod with the regulator attached as it appears from the inside of the helmet. The numbers indicate the order in which the screws and nuts that retain the pod are loosened to disconnect the pod from the helmet. Loosen the screws gradually, moving from one to another.*

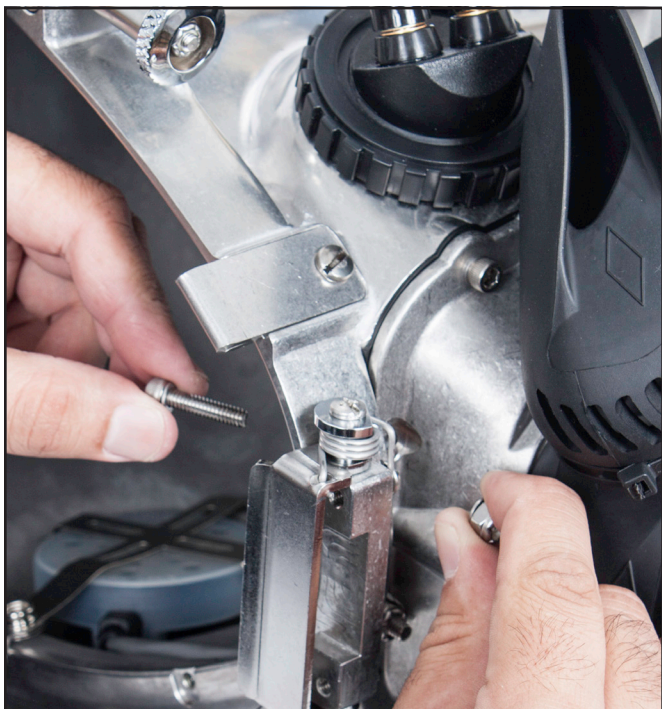

*The two nuts below the regulator are installed on the outside of the pod.*

5. Using the hex key and socket or wrench, tighten the nuts gradually in a staggered pattern, such as the one shown in the diagram on page REXPOD-5. The lock nuts should be tightened to the point where the gasket can be seen just barely starting to extrude out from between the pod and shell.

### 1.3 Reinstalling the Regulator on the Helmet



**NOTE**

If diving with a gas mixture with an oxygen percentage over 50% lubricate all O-rings and moving parts with a light coating of Christo-Lube®, Krytox®, Fluorolube®, or Tribolube®. If diving with gas mixture below 50% oxygen Dow Corning® Molykote® 111 or equivalent is suitable for O-ring lubrication.

#### Tools required:

- Tool, Regulator Mount Nut P/N 325-640
- 3/8" Ratchet Extension
- Torque Wrench
- 1/16" and 13/16" Open End Attachments
- 13/16" Open End Wrench or Backup Wrench, 47/77 P/N 540-550
- Flat Blade Torque Screwdriver

1. Inspect the regulator mount nut for contaminants and damage. Use a tooth brush to clean threads as needed. Install the regulator assembly into the helmet pod followed by the mount washer, threading the regulator mount nut as you feed the regulator assembly into the pod, hand tighten only.

2. Work around the edge of the whisker, main body, REX where it meets the helmet shell to align the rubber grooves at the back of the whisker, to the grooves on the pod. Once the regulator is correctly positioned, continue to tighten the mount nut by hand until resistance is felt.



**NOTE**

If this maintenance is during an annual overhaul, replace the Teflon® O-ring at the side block end of the bent tube and the O-ring at the demand regulator inlet side of the bent tube. If not part of annual overhaul lightly lubricate the bent tube O-ring and install into the O-ring groove at the regulator end of the bent tube, then install the Teflon® O-ring at the side block end.

### **CAUTION**

**The bent tube assembly for the KM 77 is a unique design and is not interchangeable with the bent tube assembly used on other Kirby Morgan masks and helmets.**

3. Carefully inspect the bent tube for damage and contaminants. The bent tube must be free of dents and compressions deeper than 1/8" and should not have deep scratches or sever corrosion. Replace the bent tube if questionable.

4. Install the bent tube into the inlet nipple, three or four turns. If needed, turn the regulator assembly on the helmet to allow alignment of the bent tube to the side block.

**⚠ WARNING**

All parts on Kirby Morgan helmets and masks must be adjusted to their proper torque specifications. See "Torque Specs" module for a complete listing of torque specifications for each part.

Failure to adjust parts to the recommended specifications could lead to helmet failure and accidents. This could be fatal.

5. Lightly lubricate the male threads on the side block and swing the bent tube up into place, then torque the bent tube to the side block. See "Torque Specs" module for correct torque.



*Make sure the connection between the bent tube and the regulator is snug.*

6. The whisker main body REX P/N 510-783 should have a straight angled surface from the helmet shell towards the outer edge of the regulator. Realign if needed.

7. Using two  $\frac{13}{16}$  inch wrenches or the backup wrenches from the regulator tool kit, hold the nipple tube to prevent it from rotating and tighten the bent tube nut against the nipple tube.

8. Using the Regulator Mount Nut Tool P/N 325-640 with a  $\frac{3}{8}$ " extension attached to a torque

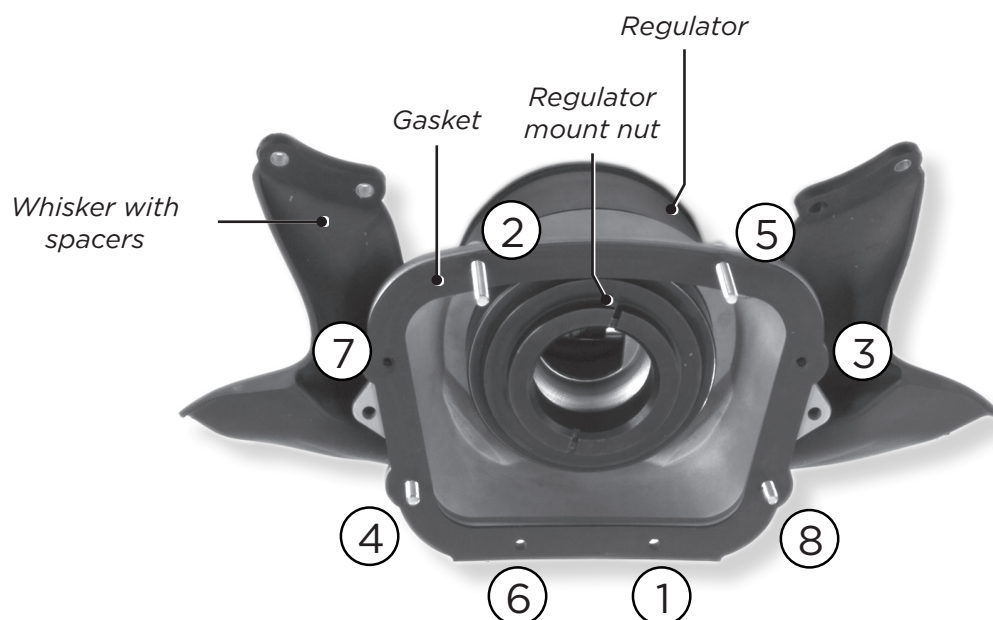

*Install and tighten the nuts and screws in a staggered pattern, as shown here. Tighten the nuts gradually so that the tension is pulled up evenly on all four sides of the pod.*

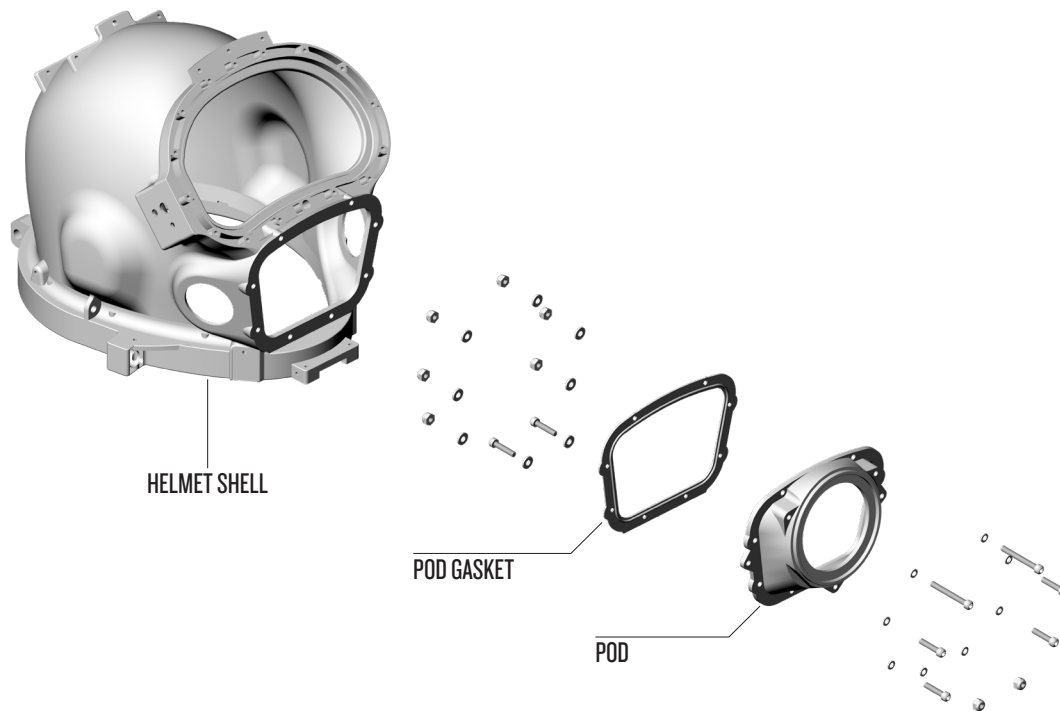

*Always remember to install the pod gasket between the pod and the helmet. Note that there are three very short screws that are fastened into the pod but that do not fasten the pod to the helmet. Two of these very short screws are just above the regulator cover, separated by 120 degrees. The third short screw is at bottom dead center just below the regulator cover. These screws will be used to attach accessories to the helmet at a future date.*

wrench, torque the regulator mount nut. See "Torque Specs" module for correct torque.



*For the regulator mount nut see "Torque Specs" module for correct torque.*

### ⚠ WARNING

**Avoid any contact between Loctite® and the face port. This can cause the port to fail unexpectedly and drowning could result.**

9. Attach the leading edge of exhaust whiskers to each side of the face port retainer using the screws, zinc anodes or kidney plates with spacers. The whiskers should have a straight angled surface from the helmet shell towards the outer edge of the regulator. Realign if needed. **For stainless steel helmets ONLY:** Place a small amount of Loctite® 248 onto the last two or three threads at the end (end opposite the screw head) of each of whisker screws. Using a torque screwdriver with a flat blade screwdriver adapter, carefully torque these screws. See "Torque Specs" module.

10. Install the oral nasal mask per "1.7.3 Oral Nasal Replacement" on page REX-16.



11. Install the nose block device per "1.2.2 Nose Block Device Replacement" on page FCPRT-6.
  
12. Install the communications module per "1.3.5 Microphone Replacement" on page COM-5.