

# Balanced SCUBA Second Stage Regulator (P/N 200-120) Maintenance Manual

## Contents

<b>1</b>	<b>1.1 General Information</b>	<b>14</b>	
1	1.1.1 Introduction		1.4.1 Assembly of the Regulator Body Subassembly
2	1.1.2 Use of Kirby Morgan Original Replacement Parts	16	1.4.2 Assembly of the Adjustment Packing Nut Subassembly
2	1.1.3 Safety Precautions		1.4.3 Assembly of the Balance Piston Subassembly
2	1.1.4 Specifications	18	1.4.4 Inlet Valve Assembly
<b>2</b>	<b>1.2 Preventative Maintenance</b>	<b>19</b>	1.4.5 Assembly of the Adjustable Nipple Subassembly
2	1.2.1 Routine Maintenance	20	1.4.6 Assembly of the Main Tube Subassembly
3	1.2.2 Scheduled Maintenance	20	1.4.7 Installing the main tube subassembly into the regulator housing subassembly
<b>3</b>	<b>1.3 Balanced SCUBA Second Stage Regulator Disassembly</b>	<b>20</b>	
3	1.3.1 General Information		
3	1.3.2 Tools Required	24	
4	1.3.3 Balanced SCUBA Second Stage Disassembly Procedure		
<b>14</b>	<b>1.4 Balanced SCUBA Second Stage Regulator Reassembly</b>	<b>30</b>	<b>1.5 Diving The Balanced SCUBA Second Stage Regulator</b>
		<b>31</b>	<b>1.6 Balanced SCUBA Regulator Assembly BlowApert</b>

## 1.1 General Information

### 1.1.1 Introduction

The Kirby Morgan Balanced SCUBA Second Stage Regulator (P/N 200-120) is a high performance scuba regulator designed for professional divers. The Balanced SCUBA Second Stage, a modified version of the same regulator used on the KM 97 helmet, is a balanced fully adjustable second stage that can be used for scuba, surface supplied full-face mask, and hookah use. This regulator was designed primarily for use with our M-48 SuperMask® and MOD-1 Full Face Masks. It is perfectly suited for surface supplied diving because of its wide range of adjustment that allows the diver to compensate for variations in supply pressure, as well as physical attitude and current.



#### NOTE

This regulator is not equipped with a “Pre-dive/dive” mechanism. It is important to pay close attention to proper techniques to prevent regulator free flow.

This manual is primarily intended to provide factory trained, authorized repair technicians and factory trained professional divers with the technical information and guidance needed to perform normal service adjustments and corrective maintenance, as well as some important basic user information to ensure proper function and use. It is strongly recommended that overhauls and repairs be completed by KMDSI authorized technicians. Owners of the Balanced SCUBA Second Stage Regulator who elect to work on their own regulators should have the proper tools, training and experience in regulator design and repair, as well as a sound technical background associated with diver life support breathing components. All repair parts should be genuine Kirby Morgan parts and

should only be obtained from authorized Kirby Morgan dealers. All authorized Kirby Morgan dealers will be found on our website [www.kirbymorgan.com](http://www.kirbymorgan.com) under “Support.”

### 1.1.2 Use of Kirby Morgan Original Replacement Parts

Users of Kirby Morgan life support equipment are cautioned to always use Kirby Morgan original replacement parts. Parts manufactured by third party companies can cause improper function, leading to accidents.



*Look for the Kirby Morgan logo on Kirby Morgan products. This is your assurance that you are getting genuine Kirby Morgan replacement parts.*

### 1.1.3 Safety Precautions

To ensure the best possible regulator performance and to avoid damage to regulator components, use only KMDSI original factory replacement parts.

To avoid damage to regulator components, only the correct size and types of tools should be used. The use of adjustable wrenches should be avoided whenever possible to avoid damage to the regulator parts.

Should you encounter technical difficulties in servicing a Kirby Morgan regulator, please contact Kirby Morgan or Dive Lab—[www.divelab.com](http://www.divelab.com) or (850) 235-2715—directly for assistance. When you call, you should have the regulator with serial number and this manual on hand for reference.

### 1.1.4 Specifications

**Second Stage Type:** Downstream, balanced bias adjustable

**Second Stage Body:** Glass fiber reinforced nylon

**Other misc. parts:** ABS + PC, PPO + GF, PPS, ABS, Titanium, POM, Nylon, polyurethane, 300 series stainless steel, liquid silicone, PP, Buna N.

Optimum intermediate working pressure: 145-150 PSI

Work of Breathing: 0.87/0.90 (AU) joules/liter at 62.5 RMV at 132 FSW

Work of Breathing: 1.0/1.1 (AU) joules/liter at 62.5 RMV at 165 FSW

## 1.2 Preventative Maintenance

### 1.2.1 Routine Maintenance

Routine maintenance is the best way to ensure long Regulator life and optimum performance.



**NOTE**

If possible, rinse while pressurized and attached to a tank. This will aid in preventing water from getting into the inlet valve. Purging the regulator after rinsing will aid in drying. Purging the regulator will likely cause free flow. This is easily stopped by slightly blocking the mouthpiece.

1) At a minimum, the regulator should be thoroughly rinsed with fresh clean water after every dive. Mild hand washing type dish soap can be used to remove grime.

### **⚠ CAUTION**

**During rinsing, if the regulator is NOT attached to an air source and pressurized, DO NOT depress the purge button on the second stage. If the hose has been removed, the fitting must be covered or capped if it will be immersed in water AND the purge button must not be depressed. Otherwise water WILL get into that balance chamber. Pressing the purge button can allow water to enter the inlet valve and possibly go into the critical balancing chamber. Water inside the balancing chamber will lead to improper regulator function, which could result in personal injury.**

2) If possible, the entire regulator should be soaked in fresh warm water, between 80–120 °F, for 15 minutes or longer. Soaking in warm water will remove salt and mineral deposits more effectively than a fresh water rinse alone.

### ⚠ CAUTION

**During soaking do not depress the purge button on the second stage. Pressing the purge button can allow water to enter the inlet valve and possibly go into the critical balancing chamber. Water inside the balancing chamber will lead to improper regulator function, which could result in personal injury.**

3) Allow the regulator to dry completely before storage. Do not leave the regulator sitting in direct sunlight. Shake the second stage to help remove water trapped inside.

4) Screw the second stage regulator adjustment knob all the way out, away from the second stage body. This will help lengthen the life of the regulator seat.

5) Ensure the regulator is completely dry before storing. Store only in a clean, cool dry place.

### ⚠ CAUTION

**Never store the regulator while still connected to a scuba cylinder. Improper care or storage of underwater breathing equipment may lead to equipment malfunction, which could result in personal injury.**

### ⚠ WARNING

**Do not carry a scuba cylinder by the regulator or hose. This abuse will lead to damage of the regulator or hose failure. Regulator or hose failure can result in personal injury or death.**

### ⚠ WARNING

**DO NOT use cleaning solvents on any parts or components of this regulator. The use of solvents may lead to failure of the regulator parts and regulator malfunction, which could cause serious injury or death.**

### ⚠ CAUTION

**NEVER pressurize the first stage regulator without having a second stage attached. This can lead to a sudden burst of high pressure air, causing the hose(s) to whip about, which could cause personal injury.**

## 1.2.2 Scheduled Maintenance

Do not assume that a regulator is in good working order because of infrequent use. Prolonged or improper storage can still result in O-ring deterioration or internal corrosion that could result in poor performance.

1) The minimum maintenance suggested for all regulators is an annual inspection and service. However, regulators that are used frequently or under severely harsh environmental conditions should be serviced more often. For example, a regulator used as a rental or for training purposes may require service every two to three months or more. Whenever a regulator has been inactive for longer than three months, it should be carefully inspected and surface checked prior to use.

## 1.3 Balanced SCUBA Second Stage Regulator Disassembly

### 1.3.1 General Information

Changes in regulator performance will be most noticeable when the second stage is out of adjustment or needs service. Careful set-up and adjustment of the second stage is essential to maximize the full performance potential.

### 1.3.2 Tools Required

The following tools are required to properly disassemble the Balanced SCUBA Second Stage:

- Open end wrenches:  
5/8", 11/16" (2), 15/16"
- Small Flat Blade Screwdriver
- Medium Flat Blade Screwdriver
- Tapered Wooden Dowel (e.g.,  
Wooden Chopstick)
- 7/64" Hex Wrench
- Diagonal Cutting Pliers

### 1.3.3 Balanced SCUBA Second Stage Disassembly Procedure

1) Remove the hose protector from the regulator assembly.



*It is sometimes easier to use a shop towel to provide a more positive grip when removing the hose protector.*

2) Using two 11/16 inch wrenches remove the L.P. hose.



*Loosen the hose nut.*



*Remove the L.P. hose.*

3) Using an 11/16 inch wrench, loosen the jam nut and remove it.



*Loosen the jam nut and remove it.*

4) Cut and remove the mouthpiece tie wrap and mouthpiece.



*Cut and remove the mouthpiece tie wrap and mouthpiece.*

5) Grip the regulator shroud/exhaust cover as shown, and pull it down and away from the remaining assembly and set aside.



*Pull the regulator shroud/exhaust cover down and away from the remaining assembly and set aside.*

6) Using a  $\frac{7}{64}$  inch hex wrench, remove the adjustment knob screw and remove the adjustment knob and set aside.



*Remove the adjustment knob screw.*



*Using the palm of your hand loosen and remove the diaphragm retainer ring.*



*Remove the adjustment knob.*



*Adjustment knob screw and adjustment knob.*



*Remove the surge dam.*

7) Remove the diaphragm retainer ring, surge dam and diaphragm washer.



*Remove the diaphragm washer.*

8) Remove the diaphragm. After removal, check it carefully to be certain it has not been damaged. If needed, replace the diaphragm.



*Remove the diaphragm.*

9) Using a small flat blade screwdriver, insert the tip into the slot at the top of the packing lock clip to loosen it and slide away from the regulator main tube.

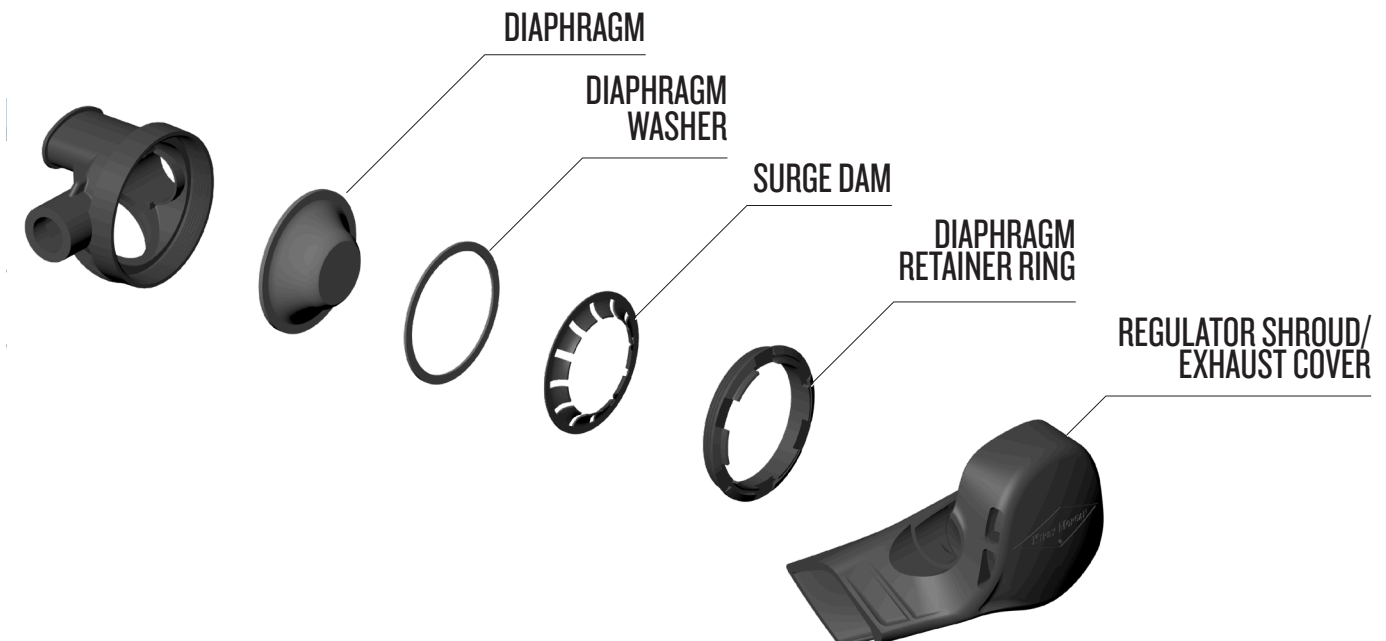

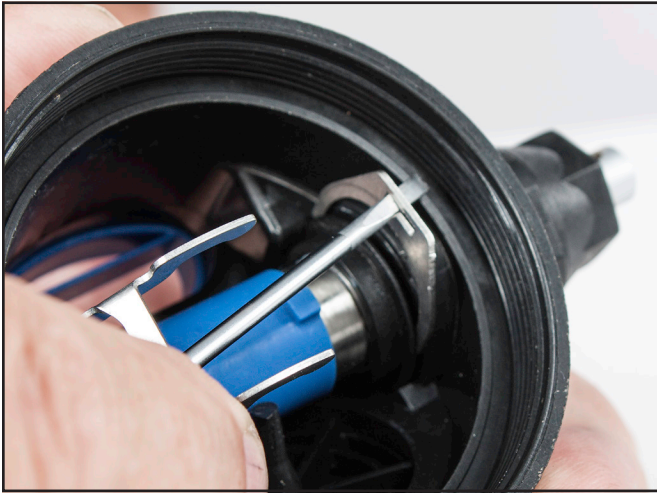

*Using a small flat blade screwdriver, remove the Packing Lock Clip.*



*Loosen the adjustment guide insert by about three full turns.*

10) Using a  $\frac{5}{8}$  inch wrench, loosen the end cap packing nut, but leave it in place.

12) While depressing the lever arm push on the threaded hose end of the main tube to dislodge this sub assembly then pull it straight out from the regulator housing.



*Loosen the End Cap Packing Nut, but leave it in place.*

11) Using a  $\frac{15}{16}$  inch wrench, loosen the adjustment guide insert by about three full turns.



**NOTE**

The lever arm will be a tight fit through the end passage of the regulator housing, but a little extra, careful effort should pull it through the opening.





*Remove the retaining ring.*

14) Remove the exhaust valve insert and exhaust valve together.



*Remove the exhaust valve insert and exhaust valve together.*

15) Carefully remove the O-ring for the exhaust valve insert making sure not to damage the sealing surface.



*Push on the threaded hose end of the main tube while depressing the lever arm then pull it straight out from the regulator housing.*

13) Using a small flat blade screwdriver, remove the retaining ring.



*Carefully remove the O-ring for the exhaust valve insert.*

16) Separate the exhaust valve insert and exhaust valve.



*Separate the exhaust valve insert and exhaust valve.*

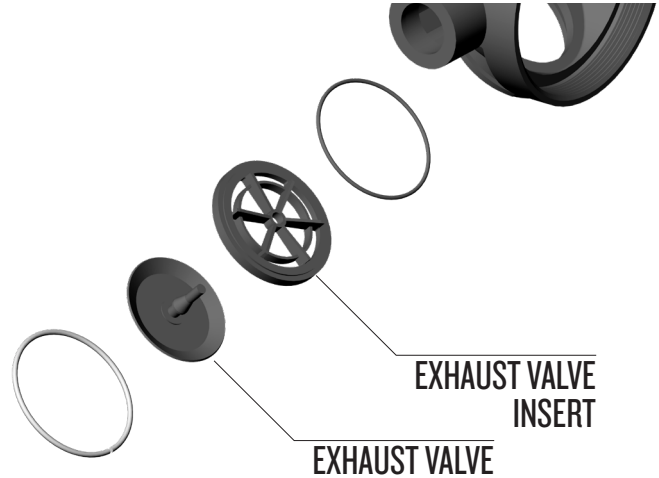

*Exhaust valve insert and exhaust valve.*

17) Separate the adjustment packing nut assembly from the end of the main tube.



*Separate the adjustment packing nut assembly from the end of the main tube.*

18) Remove the balance spacer and spring. Remove the small O-ring from the balance spacer.



*Remove the balance spacer, spring and washer.*



*Remove the lever bearing clip from the main tube.*

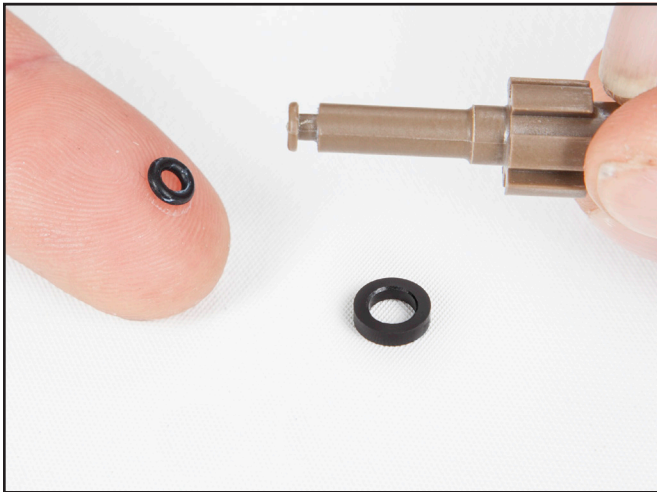

*Remove the spring, small O-ring and washer from the balance spacer.*

19) Remove the lever bearing clip from the main tube.

20) Remove the lever arm.



**NOTE**

Just barely remove one leg from the main tube slot, and allow the small end of the leg to hold against the side of the main tube, then carefully remove the second leg the same way, and the lever arm should now be free of the main tube. Remove and set aside.



*Remove the lever arm.*

21) Remove the inlet valve assembly from the main tube. Separate the valve seat from the inlet valve.



Remove the inlet valve assembly from the main tube.



Using a medium size flat blade screwdriver, loosen the adjustable nipple.



Separate the valve seat from the inlet valve.



Push the adjustable nipple out with a wooden dowel or chop stick to prevent damage to the sealing edge of the nipple

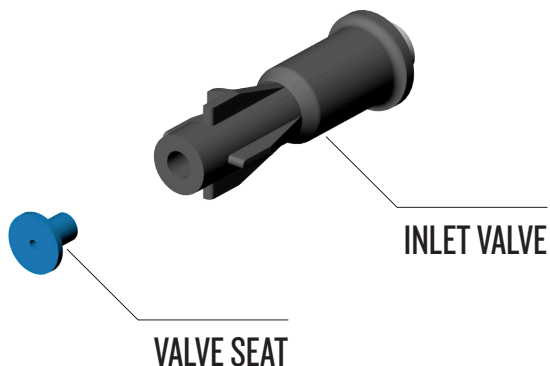

23) Remove the O-ring from the main tube.



**NOTE**

DO NOT attempt to remove the blue colored flow sleeve. This has been locked into position and should not need removal. Changing its position will influence regulator performance, so it should not be moved.

22) Using a flat blade screwdriver, loosen (counter clockwise) the adjustable nipple, enough so that it can be pushed from the main tube using a wooden dowel (or the eraser end of a pencil), to prevent damage to the sealing edge of the adjustable nipple. Remove the O-ring from the adjustable nipple.

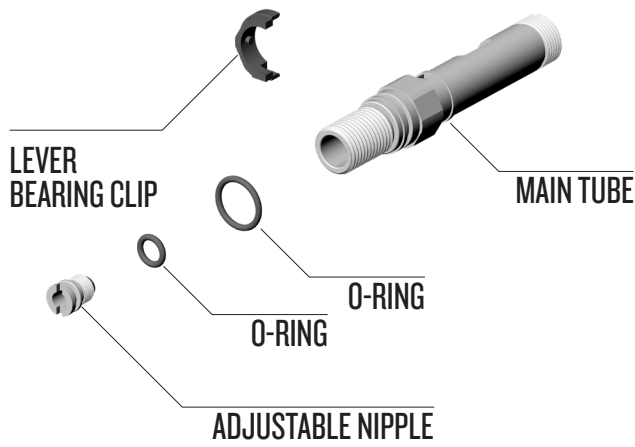

*Remove the adjustment shaft.*



*Remove the O-ring from the main tube.*

24) Remove the end cap packing nut (this may require using the 5/8 inch and 15/16 inch wrenches) and remove the adjustment shaft. This will have the spring seat, O-ring, adjustment shaft and thrust washer attached to it. Separate all of these parts.



*Separate the spring seat.*



*Remove the end cap packing nut.*



*Separate the thrust washer.*



Separate the spacer.



Remove the O-ring from the adjustment guide insert.



Remove the O-ring.

25) Remove the O-ring from the adjustment guide insert.

## 1.4 Balanced SCUBA Second Stage Regulator Reassembly

Clean and inspect all parts. Replace all O-rings and any other parts that show signs of wear.



The flow sleeve and flow baffle (blue color) are non serviceable. Do not attempt to remove these!!

**NOTE**

### 1.4.1 Assembly of the Regulator Body Subassembly

Parts included:

- Regulator Housing
- O-ring
- Exhaust Valve Insert
- Exhaust Valve
- Retaining Ring.



The flow baffle is permanently installed into the regulator housing.

**NOTE**

1) Install the O-ring into the flange area. **DO NOT LUBRICATE THIS O-RING.**



Install O-ring into the flange area. **DO NOT LUBRICATE THIS O-RING.**

2) Install the exhaust valve insert. Make certain the part is correctly oriented.



Install the exhaust valve insert.

3) Install the retaining ring into its groove.

Using a small screwdriver, or long nose pliers can make this easier. It is VERY important to be certain the retaining ring is properly installed. Improper installation could result in leakage causing possible regulator flooding or loss of the exhaust valve. If the ends of the retaining ring are too close to each other, this is an indication the retaining ring may not be installed properly. There should be a gap between the ends as shown in the following photo.



Install the retaining ring.



Using a small screwdriver, or long nose pliers can make this installation easier.



There should be a gap between the ends of the retaining ring as shown here and the bent end of the clip should not interfere with the exhaust valve after it has been installed.

4) Install the exhaust valve and cut off the excess material as shown.



*Install the exhaust valve and cut off excess material.*



*Lubricate O-ring and install onto the adjustment guide insert.*

### 1.4.2 Assembly of the Adjustment Packing Nut Subassembly

Parts included:

- O-ring
- Adjustment Guide Insert
- Spring Seat
- O-ring
- Adjustment Shaft
- Spacer
- Thrust Washer
- End Cap Packing Nut

1) Lubricate the O-ring and install onto the adjustment guide insert.

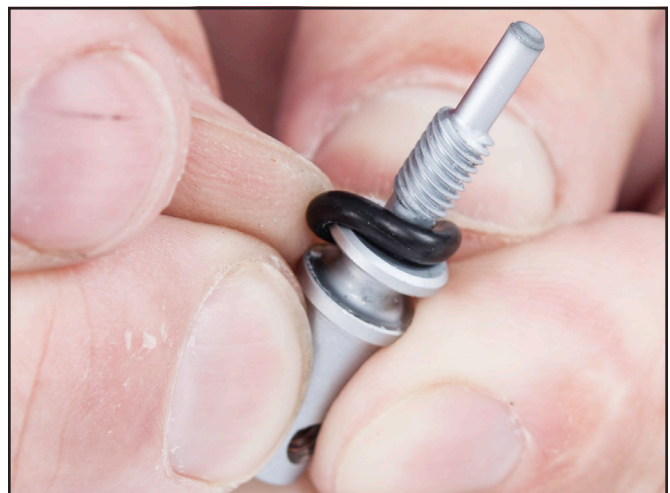

*Lubricate O-ring and install onto the adjustment shaft.*

3) Look closely at the spring seat. One end is flat and the opposite end has a recess. Lightly lubricate the threads on the adjustment shaft and install the spring seat, flat end onto the threads of the adjustment shaft and thread it on all the way until it stops. Check the movement of the threads for smooth operation. Afterwards, when threaded all the way on, check again for smooth operation of the threads.





*Look closely at the spring seat one end is recessed (shown above) and the other is flat.*

adjustment shaft. Insert all the components on this shaft into the adjustment guide insert and push all the way in.



*Install the spacer and thrust washer onto the adjustment shaft.*



**Recessed Side**



*Insert all of the components on the adjustment shaft into the adjustment guide insert.*



*Install the spring seat, **FLAT END** onto the threads of the adjustment shaft and thread it on all the way until it stops.*

4) Install the spacer and thrust washer onto the



*Push all of the components on the adjustment shaft into the adjustment guide insert.*

5) Install the end cap packing nut over the adjustment shaft, onto the threads and hand tighten as much as possible.



*Install the end cap packing nut over the adjustment shaft.*



*Hand tighten the end cap packing nut as much as possible.*

### 1.4.3 Assembly of the Balance Piston Subassembly

Parts included:

- O-ring, Balanced
- Washer



This washer to be used only with the (brown) Balance Spacer

- Balance Spacer

1) Install the washer onto the balance spacer.



*Install the washer onto the balance spacer*

2) Lightly lubricate the O-ring and install onto the

balance spacer. Lubricate the O-ring, as shown, after installation.

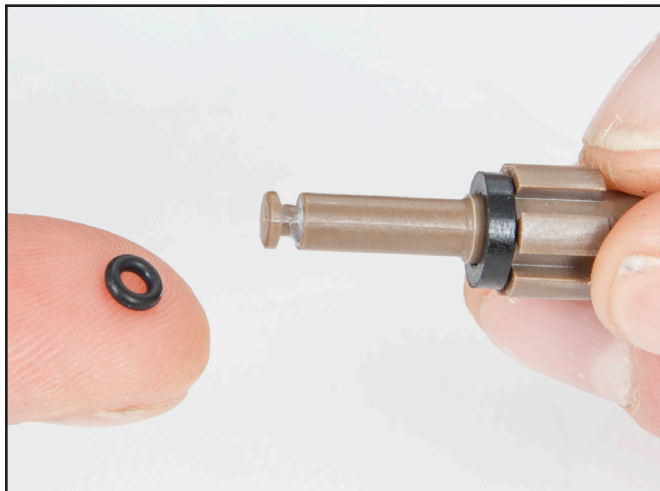

*LIGHTLY lubricate the O-ring and install onto the balance spacer.*

#### 1.4.4 Inlet Valve Assembly

Parts included:

- Valve Seat
- Inlet Valve

Check the seat before installation, to make sure the balance hole goes all the way through without anything blocking this passage.

1) Install the valve seat onto the inlet valve. **DO NOT LUBRICATE THE VALVE SEAT.** Make certain there is no space between these two parts. The valve seat must be pressed all the way into the inlet valve.



*Assemble the valve seat to the inlet valve.  
**DO NOT LUBRICATE THE SEAT.***



*Make certain there is NO space between the valve seat and inlet valve.*

### 1.4.5 Assembly of the Adjustable Nipple Subassembly

Parts included:

- Adjustable Nipple
- O-ring

1) Carefully inspect the sealing edge of the adjustable nipple using either a magnifying glass or using a fingernail against the edge while rotating the part to check for nicks or cuts.

2) VERY lightly lubricate the O-ring and install onto the adjustable nipple.



*VERY lightly lubricate the O-ring and install onto the adjustable nipple.*

### 1.4.6 Assembly of the Main Tube Subassembly

Parts included:

- [Adjustable Nipple and O-ring]
- O-ring
- Lever Bearing Clip
- Main Tube
- Flow Sleeve
- [Valve Seat and Inlet Valve]
- Inlet Valve Assembly
- Spring
- [O-ring, Balanced, Washer and Balance Spacer]

- [O-ring, Adjustment Guide Insert, Spring Seat, O-ring, Adjustment Shaft, Spacer, Thrust Washer and End Cap Packing Nut]

1) Insert the adjustable nipple subassembly into the main tube and using a medium flat blade screwdriver, thread in about three full turns.



*Insert the adjustable nipple subassembly into the main tube.*



*Using a medium flat blade screwdriver, thread in about three full turns.*

2) Lightly lubricate and install O-ring onto the main tube end as shown.



*Lightly lubricate and install O-ring onto the main tube end.*

3) Note the orientation of the lever arm to the main tube. The arms of the lever arm should be on the side of the main tube that has the relief step.



*Note the orientation of the lever arm to the main tube.*

4) Insert the balance spacer subassembly, into the inlet valve assembly up to the O-ring as shown. This will serve as a simple installation tool.

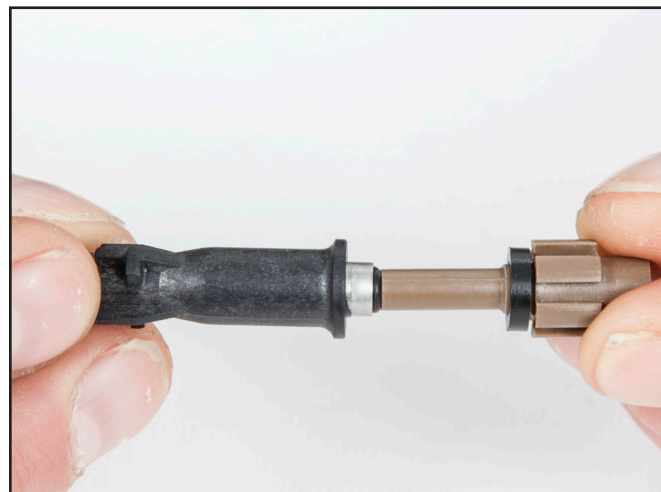

*Insert the balance spacer subassembly, into the inlet valve assembly up to the O-ring.*

5) Notice the detail features on the inlet valve. The small ribs, shown in the following photos, **MUST** face towards the bottom of the main tube to properly engage with the lever arm. **THIS IS CRITICAL!**

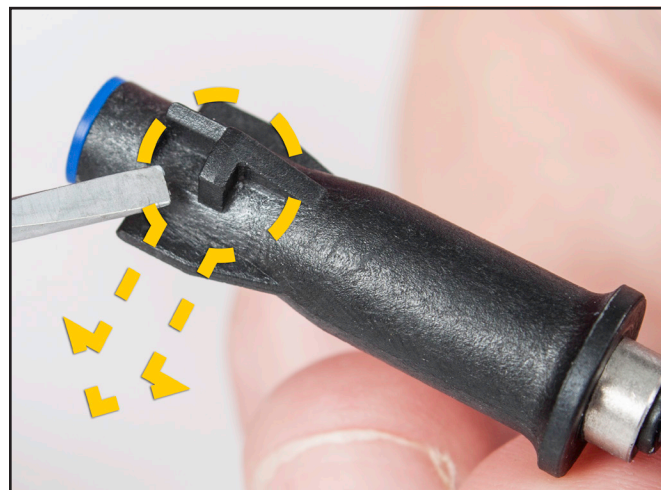

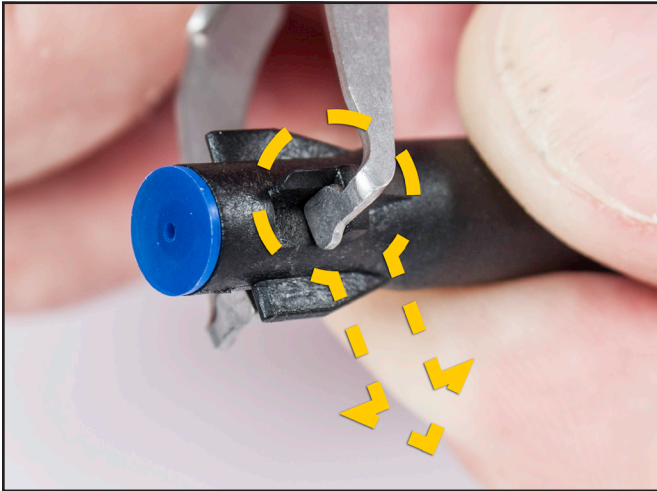

*The small ribs that are shown here, MUST face towards the bottom of the main tube, to properly engage with the lever arm.*

6) Push the inlet valve assembly inward and it will engage the legs on the lever arm. The lever arm should rise up. Continue to push a little further and the lever arm will drop down.

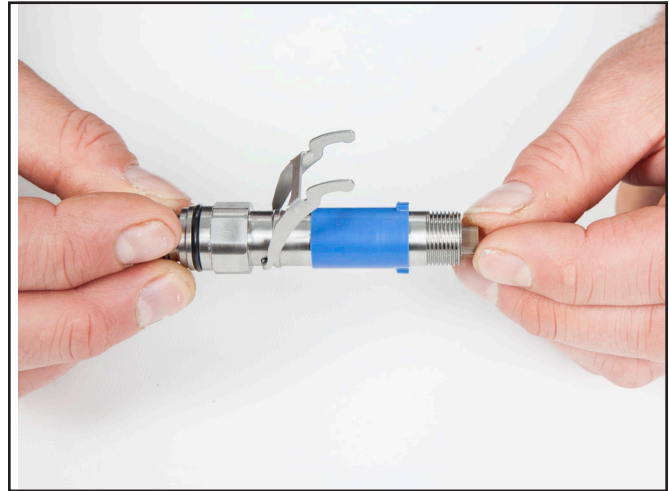

*The lever arm should rise up. Continue to push a little further and the lever arm will drop down.*

7) Pinch both sides of the lever arm against the main tube, and at the same time, remove the balance spacer with O-ring. The inlet valve assembly should remain inside the main tube. This is an indication the lever arm and inlet valve assembly are properly aligned and engaged. If the inlet valve assembly comes out when removing the balance spacer, it was not installed properly. Repeat as necessary to gain proper installation.

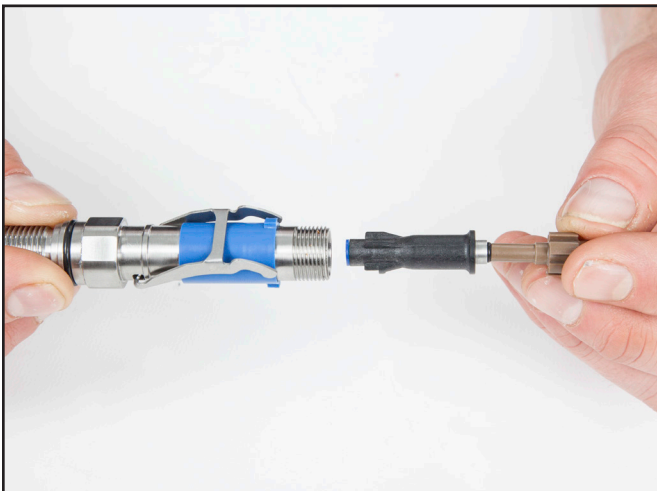

*Push the inlet valve assembly inward and it will engage the legs on the lever arm.*

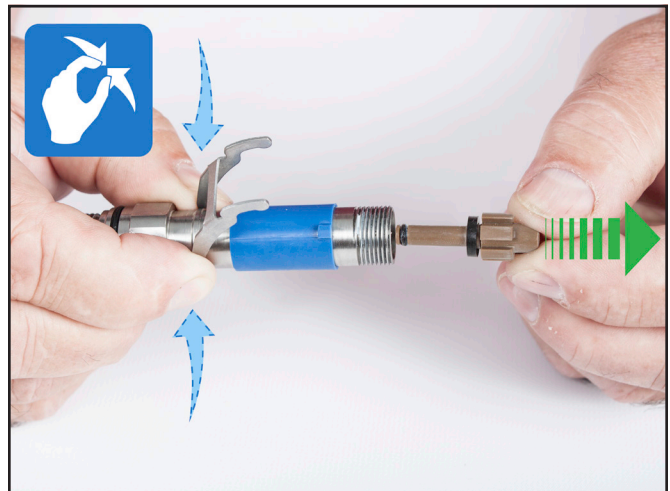

*Pinch both sides of the lever arm against the main tube, and at the same time, remove the balance spacer with O-ring.*



*With proper engagement of the lever arm to the inlet valve assembly, the inlet valve assembly should remain inside the main tube when tilted down.*

8) Apply extra lubrication to the O-ring on the balance spacer, but no more than shown. Excess lubrication could possibly block the orifice and cause erratic regulator performance.



*Apply extra lubrication to the O-ring on the balance spacer, but no more than shown.*

9) Place the spring onto the balance spacer and insert into lever arm should raise up and down with "in and out" insertion of the spring and part with it.



*Place the spring onto the balance spacer and insert into the main tube to engage the inlet valve.*

10) Install the adjustment packing nut subassembly onto the end threads of the main tube, and engage about two full turns. This will allow enough easy movement of the lever arm so the lever bearing clip can now be installed.



*Install the adjustment packing nut subassembly onto the end threads of the main tube and engage about two full turns.*

11) Note the orientation of the lever bearing clip to the hex and alignment hole that is on the main tube near the lever arm holes. Press the clip onto the main tube and make sure the parts all align.



*Note the orientation of the lever bearing clip to the hex and alignment hole that is on the main tube near the lever arm holes.*

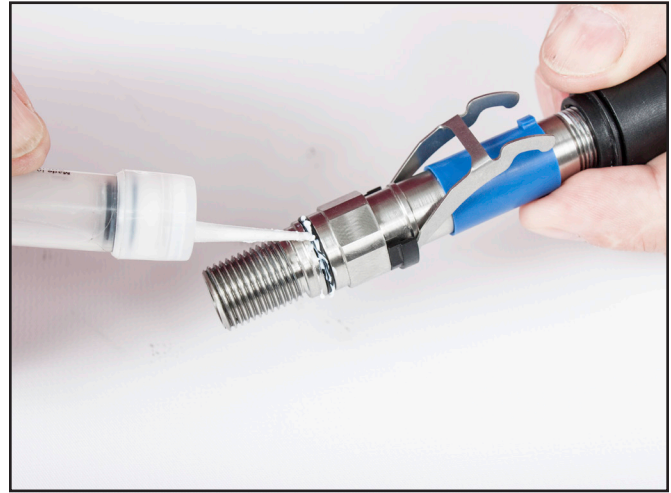

*Apply extra lubrication to the O-ring on the threaded end of the main tube.*



*Press the lever bearing clip onto the main tube and make sure the parts all align.*

### **1.4.7 Installing the main tube subassembly into the regulator housing subassembly**

1) Apply extra lubrication to the O-ring on the threaded end of the main tube.

2) Insert the main tube assembly into the regulator housing, as shown in the following images. There may be slight resistance as the lever arm passes through the large side opening on the regulator housing. Push up slightly on the main tube, while pushing the tube inward. This will aid in clearing the lever arm through.



*Insert the main tube assembly into the regulator housing.*





*Push up slightly on the main tube, while pushing the main tube inward. This will aid in clearing the lever arm through.*

3) Push the main tube in far enough so the end of the main tube hex, aligns with the outer flat on the side tube of the regulator housing, as shown.

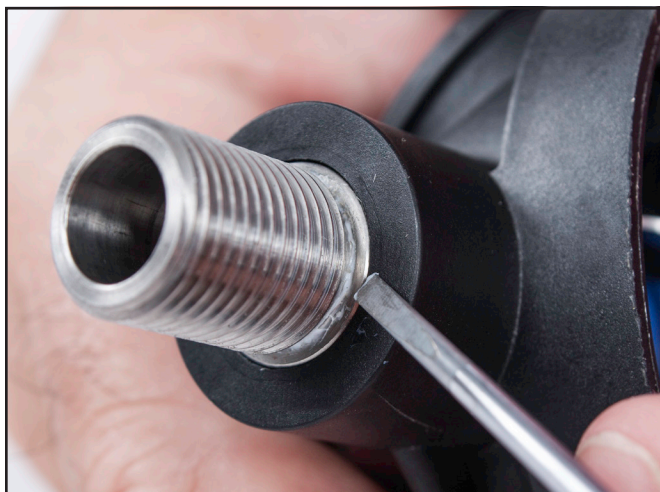

*Push the main tube in far enough so the end of the main tube hex, aligns with the outer flat on the side tube of the regulator housing.*

4) Install the jam nut and tighten with an  $\frac{1}{16}$  inch attachment on a torque wrench, to 12 in/ lbs.

5) Torque the opposite end hex of the end cap packing nut with a  $\frac{5}{8}$  inch attachment on a torque wrench, to 8 in/lbs.



*Torque the opposite end hex of the end cap packing nut.*

6) Push the locking clip in place. There must be resistance when installing this part. Make sure it is fully engaged into its mating groove.



*Push the locking clip in place.*

7) Install the adjustment knob onto the adjustment shaft and install the knob screw using the  $\frac{7}{64}$ " hex wrench. Tighten until the top of the hex end is just barely below the outer surface of the adjustment knob. At this point, the threads on the screw have engaged the adjustment knob to hold the screw from coming loose.



*Install the knob screw using the  $\frac{7}{64}$  inch hex wrench.*



*Tighten until the top of the hex end is just barely below the outer surface of the adjustment knob.*

8) Do a preliminary adjustment to the regulator by turning the adjustment knob out completely, then in  $\frac{1}{2}$  turn. Using a medium flat blade screwdriver, rotate the adjustable nipple inward, (clockwise) slowly while observing the lever arm for ANY slight movement. When the movement is detected, there should then be very slight play in the lever arm. You should be able to move the lever end about  $\frac{1}{4}$  inch without feeling spring tension.



*Using a medium flat blade screwdriver, rotate the adjustable nipple inward, (clockwise) slowly while observing the lever arm for ANY slight movement.*

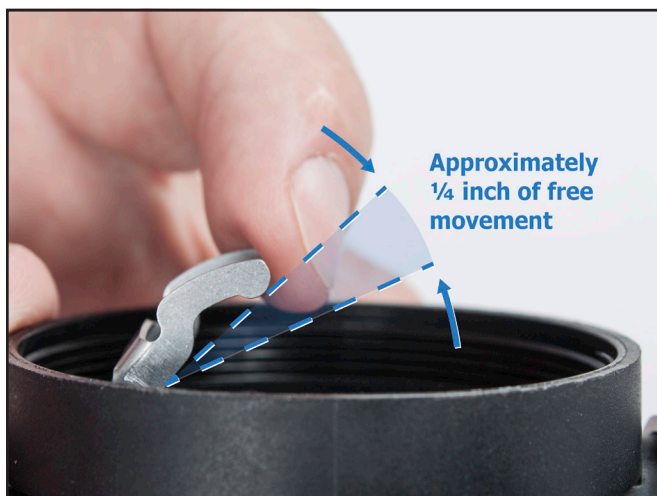

*You should be able to move the end of the lever arm about  $\frac{1}{4}$  inch without feeling spring tension.*

9) Attach an air source to the threaded end of the main tube and supply 135 to 145 psi. Check the movement of the lever arm to see where the air just begins to flow. If correctly adjusted, air flow should barely start as the lower lobes of the lever arm align with the very top edge of the regulator housing. Readjust the adjustable nipple as necessary until the desired adjustment (movement of the lever arm), is achieved.

10) Install the diaphragm, diaphragm washer, diaphragm surge dam and diaphragm retainer ring. Tighten the ring with the palm of the hand until this ring and the regulator housing top surface make contact. There should be no gap between these parts.



*Install the diaphragm.*



*Install diaphragm retainer ring.*



*Install the diaphragm washer.*



*Tighten the diaphragm retainer ring with the palm of the hand until this ring and the regulator housing top surface make contact.*



*Install diaphragm surge dam.*

11) Notice the important standoff features of the inside of the regulator shroud/exhaust cover and the recessed groove on the diaphragm retaining ring. These must be checked after installation to be sure they are correctly positioned. Install the cover onto the assembled regulator as shown. Engage the lower flange on the regulator into the groove of the regulator shroud/exhaust cover and rotate the two parts together. Stretch the upper portion of the regulator shroud/exhaust cover over the top of the regulator and make certain all areas between the two are aligned and mating.



*Notice the important standoff features of the inside of the regulator shroud/exhaust cover.*



*Rotate the regulator into the exhaust cover.*



*Notice the recessed groove on the diaphragm retaining ring.*



*Continue pushing the cover onto the regulator.*



*Engage regulator flange and exhaust cover here*



*Stretch the upper portion of the regulator shroud/exhaust cover over the top of the regulator and make certain all areas between the two are aligned and mating. Correct alignment/position of the cover and regulator.*

12) Check inside the water passages on the sides of the regulator shroud/exhaust cover to be sure the standoffs align properly with the recessed groove on the diaphragm retaining ring. If they need to be aligned, this is easily done by using a blunt ended tool such as the  $\frac{7}{64}$  inch hex wrench.



*Be sure the standoffs align properly with the recessed groove on the diaphragm retaining ring.*

13) Install the mouthpiece, and tie wrap. Position the block on the tie wrap so it won't interfere with the diver, and trim the excess as close to the block as possible to avoid sharp edges.



*Install the mouthpiece.*



*Install the tie wrap.*

14) Re-attach the air supply and re-check the regulator to be sure it is adjusted correctly and is not leaking air. Purge the regulator to be certain it is stable. Very slight depression of the cover should start airflow. This regulator WILL FREE FLOW when it is being checked if the mouthpiece is not slightly blocked. Test the regulator purge without blocking it. The free flow should stop by simply blocking the mouthpiece.

**NOTE**

To simplify the assembly and the use of this high performance regulator, it does not incorporate a “pre-dive/dive” mechanism. The adjustment knob has a “rapid travel” design that allows very quick spring pressure to be applied or decreased to the inlet valve. Turning the adjustment knob three or more turns in, (clockwise) will increase tension on the valve. Doing this and slightly blocking the mouthpiece will eliminate the possibility of the regulator free flowing. Usually, simply blocking the mouthpiece when removing the regulator from the mouth, or when removing the M-48 SuperMask®/M-48 MOD-1 mask from the face, will prevent excess flow from the regulator. This is also true when testing the purge function of the regulator. If the regulator is in the diver’s mouth or on the mask, the regulator will not free flow.

www.kirbymorgan.com or by phone at (805) 928-7772 or Dive Lab Inc, by phone at (850) 235-2715 or www.divelab.com.

### **⚠ CAUTION**

**KMDSI strongly recommends that recreational divers dive within the recognized established maximum depth of 130 fsw (feet sea water). Failure to adhere to this depth limitation could result in accidents leading to personal injury.**

## **1.5 Diving The Balanced SCUBA Second Stage Regulator**

When diving the Balanced SCUBA Second Stage regulator, the user has the ability to desensitize the regulator for water entries and exits. It is best to turn the adjustment knob in about two turns before water entry then readjust for best breathing. This is especially useful when going through surf, or for a jump entry into the water. Once underwater, the multi turn Adjustment Knob should be set to the easiest breathing setting and comfort of the diver. For minimal breathing resistance, the Adjustment Knob should be turned out completely, then turned back in just slightly.

**NOTE**

If the diver enters the water with the regulator OUT of mouth, be certain to slightly block the Mouthpiece, as sudden water pressure on the Diaphragm from entry may cause the regulator to free flow. There is no “Pre-Dive/Dive” mechanism on this regulator.

The ability of the Balanced SCUBA Second Stage regulator to control a wide range of intermediate pressures allows it to be used with virtually any recreational or commercially available first stage regulator. The Balanced SCUBA Second Stage regulator also lends itself well to Full Face Mask use, on scuba or by means of umbilical surface supply. This regulator was designed to replace the earlier Kirby Morgan non-balanced second stage regulators previously used in the M-48 SuperMask® and M-48 MOD 1 Full Face Masks. These Masks (when ordered with regulator) are currently supplied with the Balanced SCUBA Second Stage regulator (for M-48s: order P/N 200-125 Balanced SCUBA Regulator). For further guidance and technical information please contact Kirby Morgan either through our website

# Balanced Scuba Regulator Assembly P/N 200-120

Location #	Part #	Description
1	310-278	Mouthpiece
2	520-039	Tie Wrap
3	220-086	Flow Baffle
4	220-041	Regulator Housing
5	250-031	Adjustable Nipple
6	510-010	O-ring
7	510-015	O-ring
8	220-056	Lever Bearing Clip
9	250-059	Main Tube
10	210-060	Valve Seat
11	Order 205-020	Inlet Valve Assembly
12	205-020	Inlet Valve
13	235-015	Spring
14	210-055	O-ring, Balanced

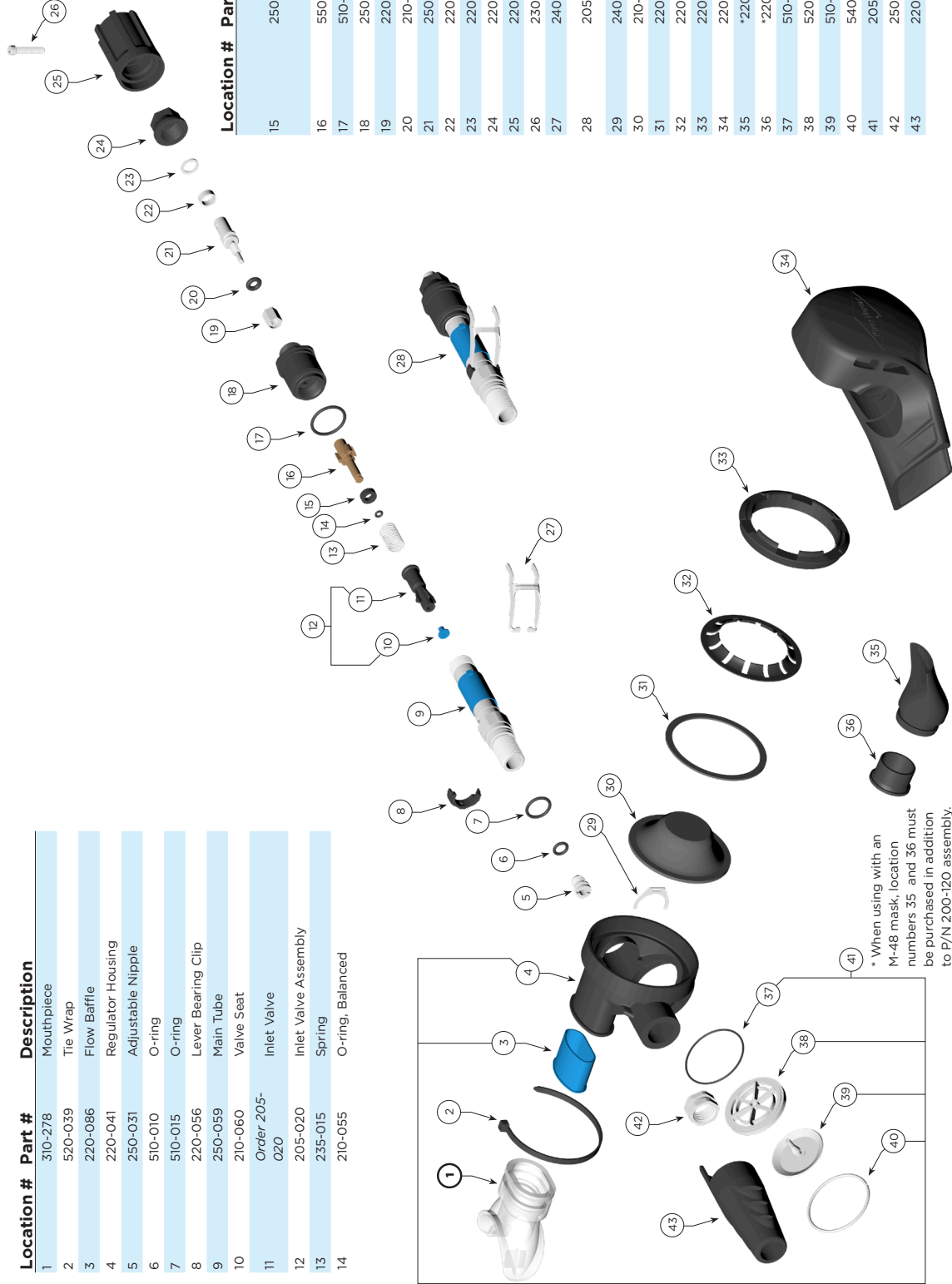

Location #	Part #	Description
15	250-065	Washer NOTE: This washer to be used ONLY with 550-549 (brown) Balance Spacer
16	550-549	Balance Spacer
17	510-018	O-ring
18	250-012	Adjustment Guide Insert
19	220-079	Spring Seat
20	210-056	O-ring
21	250-013	Adjustment Shaft
22	220-080	Spacer
23	220-031	Thrust Washer
24	220-021	End Cap Packing Nut
25	220-085	Adjustment Knob
26	230-017	Adjustment Knob Screw
27	240-008	Lever Arm
28	205-030	Main Tube Assembly (Includes loc. # 5-24 and 27)
29	240-009	Packing Lock Clip
30	210-041	Diaphragm
31	220-032	Diaphragm Washer
32	220-034	Diaphragm Surge Dam
33	220-033	Diaphragm Retainer Ring
34	220-042	Regulator Shroud/Exhaust Cover
35	*220-087	Purge Tube, Balanced
36	*220-057	Purge Sleeve, Balanced
37	510-019	O-ring
38	520-022	Exhaust Valve Insert
39	510-776	Exhaust Valve
40	540-012	Retaining Ring
41	205-025	Regulator Body Assembly
42	250-058	Jam Nut
43	220-088	Hose Protector

\* When using with an M-48 mask, location numbers 35 and 36 must be purchased in addition to P/N 200-120 assembly.